

GENERAL

M&H AWWA C508 STANDARD SWING CHECK VALVES

- ◆ Style 59-02 plain / 159-Lever & Weight / 259-02 Lever & Spring
- ◆ Sizes 2” Through 36”
- ◆ Water / Sewage Service

M&H Swing Check valves are widely specified by engineers and operating personnel. They are well proportioned and sturdily constructed - provide the ideal answer wherever check valves are needed in water and waste treatment plants.

The valve clapper swings open to allow a “Full Waterway Flow” through the valve equal to the nominal diameter of the pipe. The clapper operates freely and opens or closes in accordance with the direction of flow. Clappers for valves 2”, 2.5”, and 3” are bronze. Clappers for valves 4” through 12” are cast iron, bronze-faced. Rubber faced clappers are available on all check valves 2 ½” thru 12” and standard on 14” through 36”. For optimum performance, rubber faced clappers are recommended on all check valves 14” and larger.

Three types of M&H Check Valves are manufactured. First, the plain swing check valve which opens by line pressure and flow, and closes by gravity under a no flow condition; the clapper is lowered when the flow drops or reverses direction. The second type is outside lever-and-weight and the third type is outside lever-and-spring. These refinements are desirable to accomplish quicker closing and to minimize slamming where conditions of rapid flow reversal are encountered.

Plain, Lever and Weight, and Lever and Spring designs can be used for vertical installation. Lever-and-weight type check valves for horizontal installations require the lever arm close to parallel to the run of the pipe and the weight on the downstream side of the clapper for quick closing. For vertical installation of lever-and-weight valves, the lever arm is moved to a position perpendicular to the run of the pipe, to assist in closing.

Either lever-and-weight or lever-and-spring check valves are adjustable. Both types require field adjustment to best meet particular operating conditions. Unless otherwise ordered, the lever-and-weight or the lever-and-spring is placed on the right hand side when facing the valve inlet. Under conditions of extreme rapid flow reversal, check valves with dual lever arms can be supplied.

Stainless steel hinge pins are featured in all sizes. Check Valves 2”-12” have O-ring sealed side plugs. Levered valves use a fiber packing in its gland housing. Lever-and-weight or lever-and-spring type check valves sizes 14” through 36” using packing are regularly supplied with hinge pin extended through bronze bushing and with outside glands and rubber faced clappers.

Flanged end, increasing check valves are also available in plain, lever-and-spring or lever-and-weight configurations. These valves provide size reduction and eliminate requirements for special adapters or fittings. Increasing check valves are most often used on pump discharge outlets such as package lift stations.

Note: When lever-and-weight or lever-and-spring check valves are to be specified or used, we recommend lever-and-spring over lever-and-weight for all 14” and larger. In addition, rubber faced clappers should be used. As stated in AWWA C508, “Conditions of water hammer, hydraulic pulsation, and excessive operating noise are results of system design rather than valve design and are beyond the scope of this standard and require special design and construction considerations.”

Note:

It is generally recommended that when using M&H swing check valves that you locate the valve at least 5 pipe diameters downstream from any flow disturbance or obstruction (valve, pump, elbow, reducer, etc.). Turbulence close to the check valve may result in valve “chatter” resulting in premature failure of the check valve.

As stated in AWWA C508, “Conditions of water hammer, hydraulic pulsation, and excessive operating noise are results of system design rather than valve design and are beyond the scope of this standard and require special design and construction considerations.”

STYLE NUMBERS (2"-36")

M&H AWWA C508 STANDARD SWING CHECK VALVES

Size Range	Water Working Pressure psi	Seat Test Psi	Hydrostatic Shell Test psi
AWWA 2" – 12"	200	400	400
AWWA 14"-36"	150	300	300

Type / Facing Material / Options	Size Range	Style Number	Drawing Number
----------------------------------	------------	--------------	----------------

2"-12" STANDARD CHECKS

Plain / Swing Check---Rubber Faced	2"-12"	59-02A	CV-A1-PC
Plain / Swing Check---Rubber Faced—With Tapped Cover	2"-12"	59-02AT	CV-A1-PC
Plain / Swing Check---Bronze Faced	2"-12"	59-02	CV-A1-PC
Plain / Swing Check ---Bronze Faced—With Tapped Cover	2"-12"	59-02T	CV-A1-PC
Lever & Weight—Rubber Faced	2"-12"	159-02A	CV-A1-LW
Lever & Weight—Rubber Faced—With Limit Switch	2"-12"	159-02ALS	CV-A1-LW
Lever & Weight—Rubber Faced—With Dual Arm	6"-12"	159-02AD	CV-A1-LW
Lever & Weight—Bronze Faced	2"-12"	159-02	CV-A1-LW
Lever & Weight—Bronze Faced—With Limit Switch	2"-12"	159-02LS	CV-A1-LW
Lever & Weight—Bronze Faced—With Dual Arm	6"-12"	159-02D	CV-A1-LW
Lever & Spring—Rubber Faced	2"-12"	259-02A	CV-A1-LS
Lever & Spring—Rubber Faced—With Limit Switch	2"-12"	259-02ALS	CV-A1-LS
Lever & Spring—Bronze Faced	2"-12"	259-02	CV-A1-LS
Lever & Spring—Bronze Faced—With Limit Switch	2"-12"	259-02LS	CV-A1-LS

14"-36" STANDARD CHECKS

Plain / Swing Check---Rubber Faced	14"-36"	59-02A	LCV-A1
Lever & Weight—Rubber Faced	14"-36"	159-02A	LCV-A1
Lever & Weight—Rubber Faced—With Limit Switch	14"-36"	159-02ALS	LCV-A1
Lever & Weight—Rubber Faced—With Dual Arm	14"-36"	159-02AD	LCV-A1
Lever & Spring—Rubber Faced	14"-36"	259-02A	LCV-A1
Lever & Spring—Rubber Faced—With Limit Switch	14"-36"	259-02ALS	LCV-A1
Lever & Spring—Rubber Faced—With Dual Arm	14"-36"	259-02AD	LCV-A1

Note: In addition to Dual Arms, Limit Switches & Tapped Cover, M&H also can provide check valves with special coatings and tapped bosses. See drawing CV-TB for location and sizes of tapped bosses.

Note:

It is generally recommended that when using M&H swing check valves that you locate the valve at least 5 pipe diameters downstream from any flow disturbance or obstruction (valve, pump, elbow, reducer, etc.). Turbulence close to the check valve may result in valve "chatter" resulting in premature failure of the check valve.

As stated in AWWA C508, "Conditions of water hammer, hydraulic pulsation, and excessive operating noise are results of system design rather than valve design and are beyond the scope of this standard and require special design and construction considerations."

SUGGESTED SPECIFICATIONS

M&H AWWA C508 STANDARD SWING CHECK VALVES

- ◆ Style 59-02 plain / 159-Lever & Weight / 259-02 Lever & Spring
- ◆ Sizes 2” Through 36”
- ◆ Water / Sewage Service

GENERAL Check Valves shall be all iron body, bronze mounted, full opening swing type. Valve clapper shall swing full open permitting a “full flow” thru the valve equal to the nominal pipe diameter. They shall comply with AWWA Standard C-508 latest revision.

RATING Check Valves (2” through 12”) shall be rated at 200 psi water working pressure, 400 psi hydrostatic test for structural soundness. Check valves (14” through 36”) shall be rated at 150 psi water working pressure, 300 psi hydrostatic test. Pressure testing shall be done in accordance with AWWA C508.

END CONFIGURATION Check Valves shall be furnished with 125# ANSI flanged end connections.

MATERIALS All cast iron shall conform to ASTM-A-126 Class B. Casting shall be clean and sound without defects that will impair their service.

Clappers 2”-3” shall be bronze.
Clappers 4”-12 shall be faced with bronze or rubber.
Clappers 14”-36” shall be rubber faced.

Body Rings / Seats shall be bronze.

Hinge pins shall be 18-8 stainless steel with bronze side plugs (2”-12”), or packing with a Ductile Iron packing gland with 18-8 fasteners (14”-36”).

DESIGN Check Valves shall be constructed to permit top entry for complete removal of internal components without removing the valve from the line.

Plain Check Valves 2”-12” shall have O-ring sealed side plugs.
Levered Check Valves in all sizes shall have conventional packing & packing gland design.

When specified, for application conditions of rapid flow reversal or vertical installation, check valve shall be equipped with adjustable outside lever & spring or lever & weight to accomplish faster closing and to minimize slamming effect.

All valves 14” and larger shall have extended hinge pins for future addition of levers and springs if required. Valves shall be suitable for installation in either horizontal or vertical position.

COATING The inside and outside of all valves, together with the working parts except bronze and machined surfaces, shall be coated in accordance with AWWA standards.

MARKINGS Markings shall be in accordance with AWWA C-508 and shall include size, working pressure, cast arrow to indicate direction of flow, name of manufacturer, and year of manufacture.

Note:

It is generally recommended that when using M&H swing check valves that you locate the valve at least 5 pipe diameters downstream from any flow disturbance or obstruction (valve, pump, elbow, reducer, etc.). Turbulence close to the check valve may result in valve “chatter” resulting in premature failure of the check valve.

September 1, 2012 / C508 Check Valves

14"-30" CHECK VALVE BODY

PART NO	QTY	DESCRIPTION	MATERIAL & ASTM SPEC
1	1	BODY	CI A-126 CLASS B (30" IS DI)
2	1	COVER	CI A-126 CLASS B
3	1	BODY RING	BRONZE CDA 84400
8	1	HINGE PIN	STN. STL A-276-303
9	2	GLAND	CI A-126 CLASS B
10	*	COVER BOLTS & NUTS	STEEL A-307 GRADE B
11	1	COVER GASKET	NON-ASBESTOS

14" - 30" CLAPPER ASSEMBLY

4	1	CLAPPER	CI A-126 CLASS B
5	1	CLAPPER ARM	DUCTILE IRON ASTM -536
7	*	CAP SCREW	BRONZE B-21
12	1	ENCAPSULATED RUBBER CLAPPER RING	BUNA "N" DUROMETER 70
14	*	RING CLAMP CAP SCREW	BRONZE B-21
21	1	CAP PLATE	COPPER ALLOY 864/ASTM-132

* VARIES

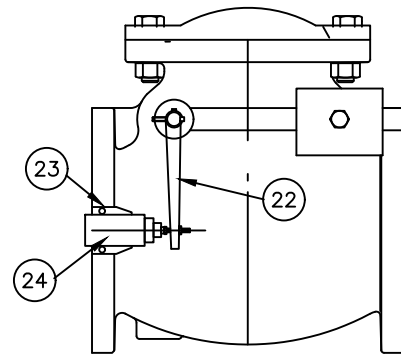

LIMIT SWITCH OPTION

22	1	TRIPPER ARM	STEEL
23	1	MOUNTING BRACKET	STEEL
24	1	LIMIT SWITCH	SD-D-TYPE-CR53E

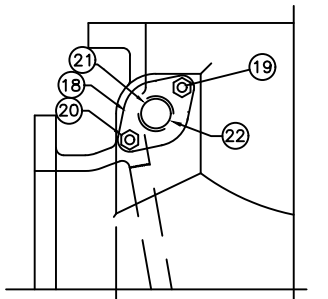

STUFFING BOX DETAILS

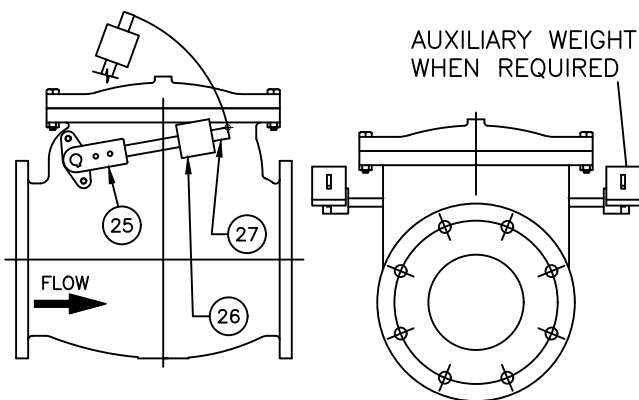
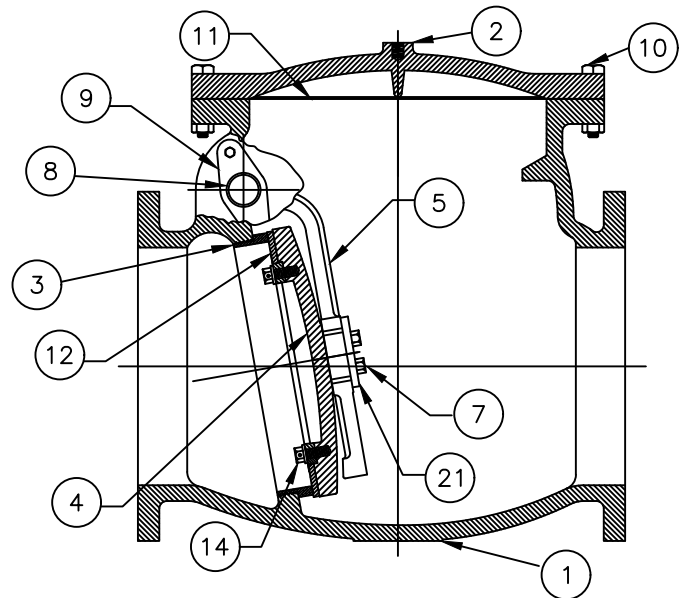

LEVER & WEIGHT CHECK VALVE

25	1	WEIGHT LEVER ARM	DUCTILE IRON
26	1	WEIGHT	FAB. STEEL
27	1	WEIGHT ARM BAR	CR STEEL C-1018/1020

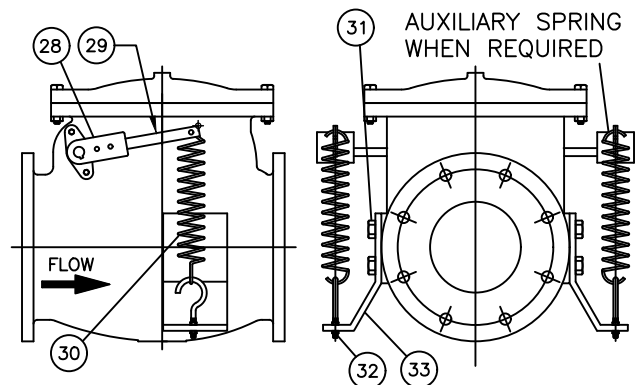

LEVER & SPRING CHECK VALVE

28	1	SPRING ARM LEVER	DUCTILE IRON
29	1	SPRING ARM BAR	CR STEEL C-1018/1020
30	1	SPRING	STEEL
31	*	SPRING BRACKET CAP SCREW	STEEL A-307 GRADE B
32	1	SPRING EYEBOLT	STEEL A-307 GRADE B
33	1	SPRING BRACKET	STEEL

* VARIES



M&H VALVE COMPANY
 A DIVISION OF McWane, Inc.
 P.O. BOX 2088
 ANNISTON, ALABAMA 36202

DWN: CTJ
 DATE: 4/17/18
 DWG. NO. LCV-A2-C

14" THRU 30" FULL WALL CHECK VALVES FLANGED ENDS - ALL STYLES MATERIAL LIST

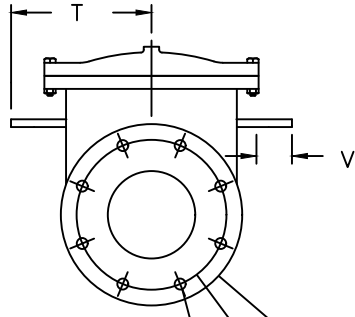
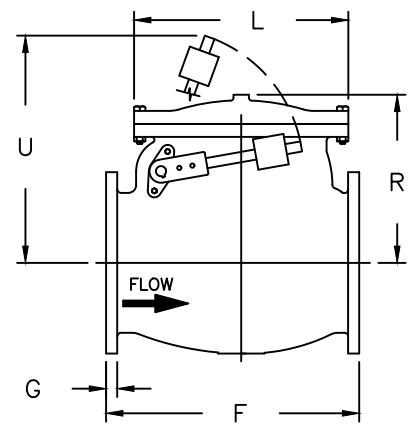
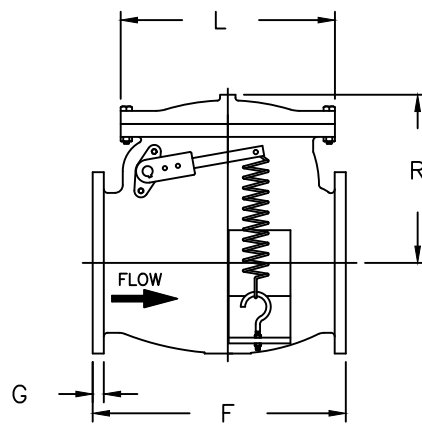
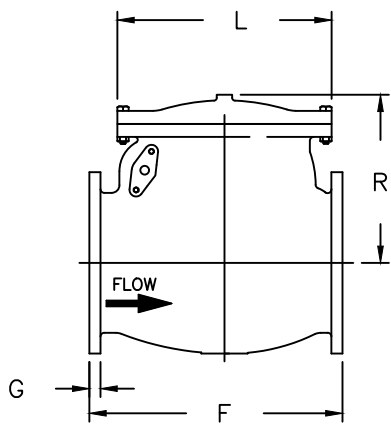

ØH O.D.
ØJ B.C.
K- NO. & DIA. OF BOLTS

PLAIN / SWING

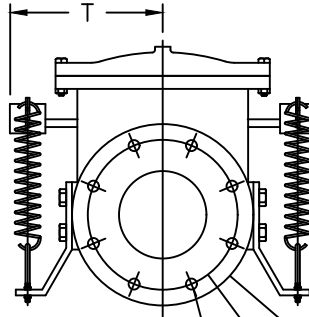

ØH O.D.
ØJ B.C.
K- NO. & DIA. OF BOLTS

LEVER & SPRING

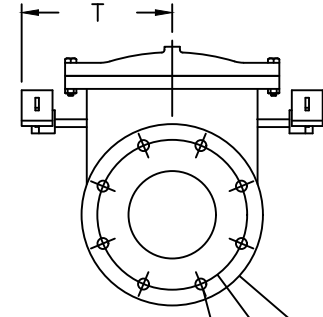

ØH O.D.
ØJ B.C.
K- NO. & DIA. OF BOLTS

LEVER & WEIGHT

VALVE SIZE	14	16	18	20	24	30
F	30	35	36 1/2	37 5/8	44	49 1/2
G	1 3/8	1 7/16	1 9/16	1 11/16	1 7/8	2 1/8
H	21	23 1/2	25	27 1/2	32	38 3/4
J	18 3/4	21 1/4	22 3/4	25	29 1/2	36
K	12-1	16-1	16-1 1/8	20-1 1/8	20-1 1/4	28-1 1/4
L	23 1/2	27 1/2	27 1/2	32	38 3/4	43 3/4
R	18 3/4	23	25	24 1/2	28	32 7/8

PLAIN / SWING CHECK VALVES--STYLE 59-02

T	18 1/2	19	20 3/4	22 1/2	26	28 1/4
WEIGHT	1060	1460	1750	2230	3040	5200

LEVER & SPRING CHECK VALVES--STYLE 259-02

T	18 1/2	19	20 3/4	22 1/2	26	28 1/4
WEIGHT	1150	1630	1835	2500	3415	4950

LEVER & WEIGHT CHECK VALVES--STYLE 159-02

T	18 1/2	19	20 3/4	22 1/2	26	28 1/4
U	32 1/2	34 1/2	40	42	54 1/2	57 1/2
WEIGHT	1130	1530	1903	2383	3298	5550

*FOR REPLACEMENT OF EXISTING 14"-30" CHECK VALVES, PLEASE CONSULT WITH FACTORY FOR POSSIBLE ALTERNATIVE LAYING LENGTH.
DIM 'V' CONSULT M&H FOR MAX. CUT-OFF OF HINGE PIN TO ELIM. CLEARANCE PROBLEMS

M&H VALVE COMPANY
ANNISTON, ALABAMA
A DIVISION OF MCWANE INC.

DWN: CTJ
DATE: 4/17/18
DWG. NO.
LCV-A1

14" THRU 30" FULL WALL CHECK VALVES FLANGED ENDS, ALL STYLES DIMENSIONS