

CLOW CANADA

100 - 300 R/W VALVE NRS
 TYTON x TAPPING ENDS
 GENERAL DIMENSIONS

PROJECT

OWNER

CONTRACTOR

DISTRIBUTOR

CONSULTANT

CLOW FIGURE F6115

CLOW MODEL 2640 AWWA C509 FULL WALL CAST IRON

CLOW MODEL 2639 AWWA C509 FULL WALL DUCTILE IRON

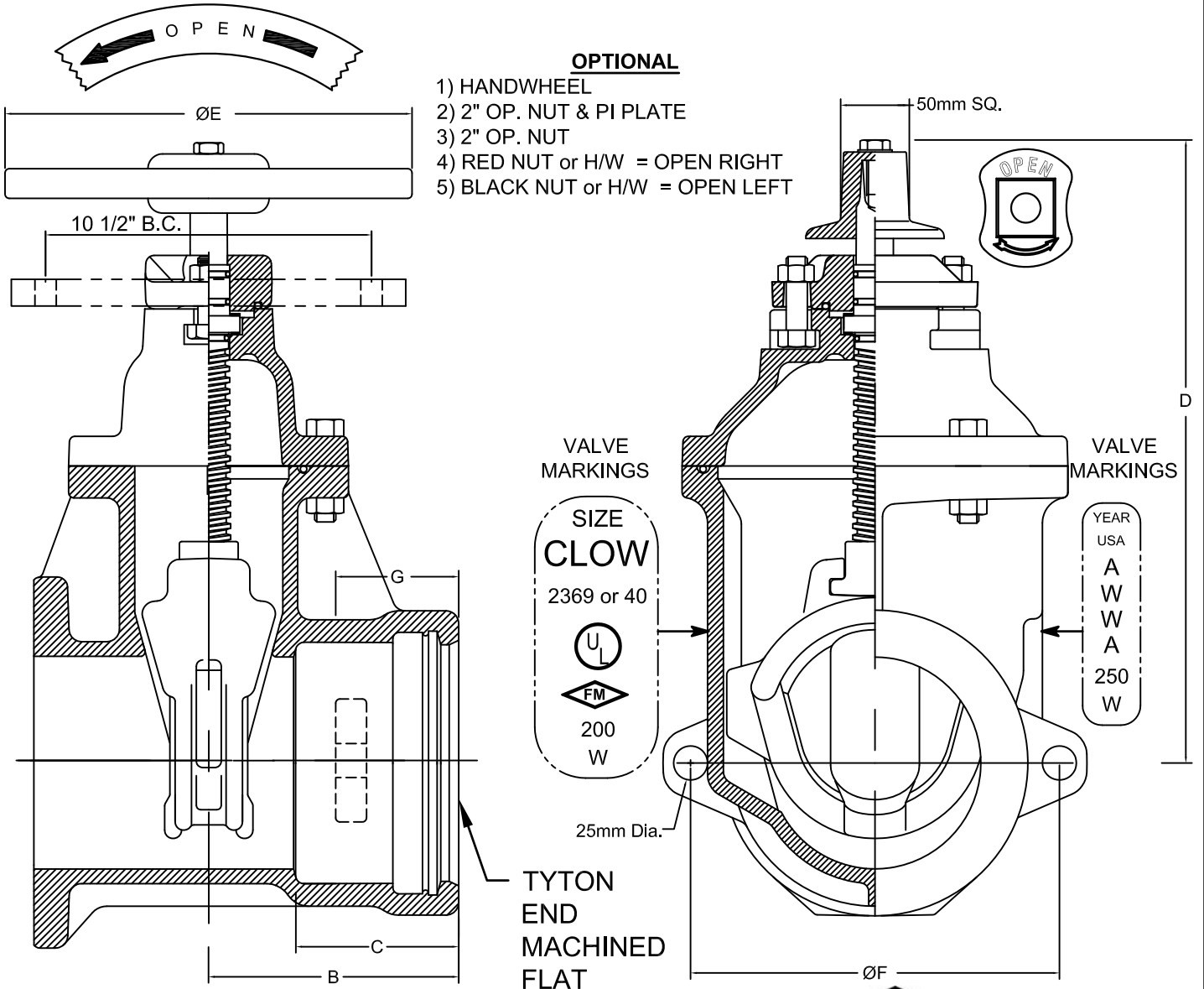

75mm TO 300mm AVAILABLE AS POST INDICATOR VALVE

METRIC DIMENSIONS							NUMBER OF TURNS	WEIGHT W/2" NUT	WEIGHT W/ HW	WEIGHT PI PLATE
VALVE SIZE	B	C	D	E	F	G				
100	165	110	375	250	210	95	13 1/2	88 lbs	94 lbs	104 lbs
150	185	120	480	300	275	95	19 1/2	138 lbs	147 lbs	154 lbs
200	215	145	570	350	325	115	25 1/2	214 lbs	226 lbs	230 lbs
250	245	155	670	450	405	130	31 1/2	360 lbs	379 lbs	376 lbs
300	265	155	760	450	470	135	37 3/4	505 lbs	524 lbs	521 lbs

Design and Materials Subject to Change Without Notice Feb. 2016