

30" - 54" R/W VALVES

KENNEDY VALVE

**KENNEDY VALVE AWWA C515 Resilient Wedge Gate Valves
Meet or Exceed the Requirements of
AWWA Standard C515**

Size Range	Water Working Pressure psi	Bubble Tight Test psi	Hydrostatic Shell Test psi
AWWA 30"-54"	250	250	500

Available End Connections & Size Range	Figure No.
Flange X Flange	30" - 54" 7561AMSS 30" - 54" 7561BMSS
M.J. X M.J.	30" - 48" 7571AMSS 30" - 48" 7571BMSS
Flange X M.J.	30" - 48" 7572AMSS 30" - 48" 7572BMSS

NOTE: A = Spur Gearing
B = Bevel Gearing

AWWA C515 REDUCED WALL DUCTILE IRON

**30" - 54" R/W VALVE
BEVEL GEAR ASSEMBLY**

KENNEDY VALVE

MODEL KS-RW/2638

Fig. 7561SS

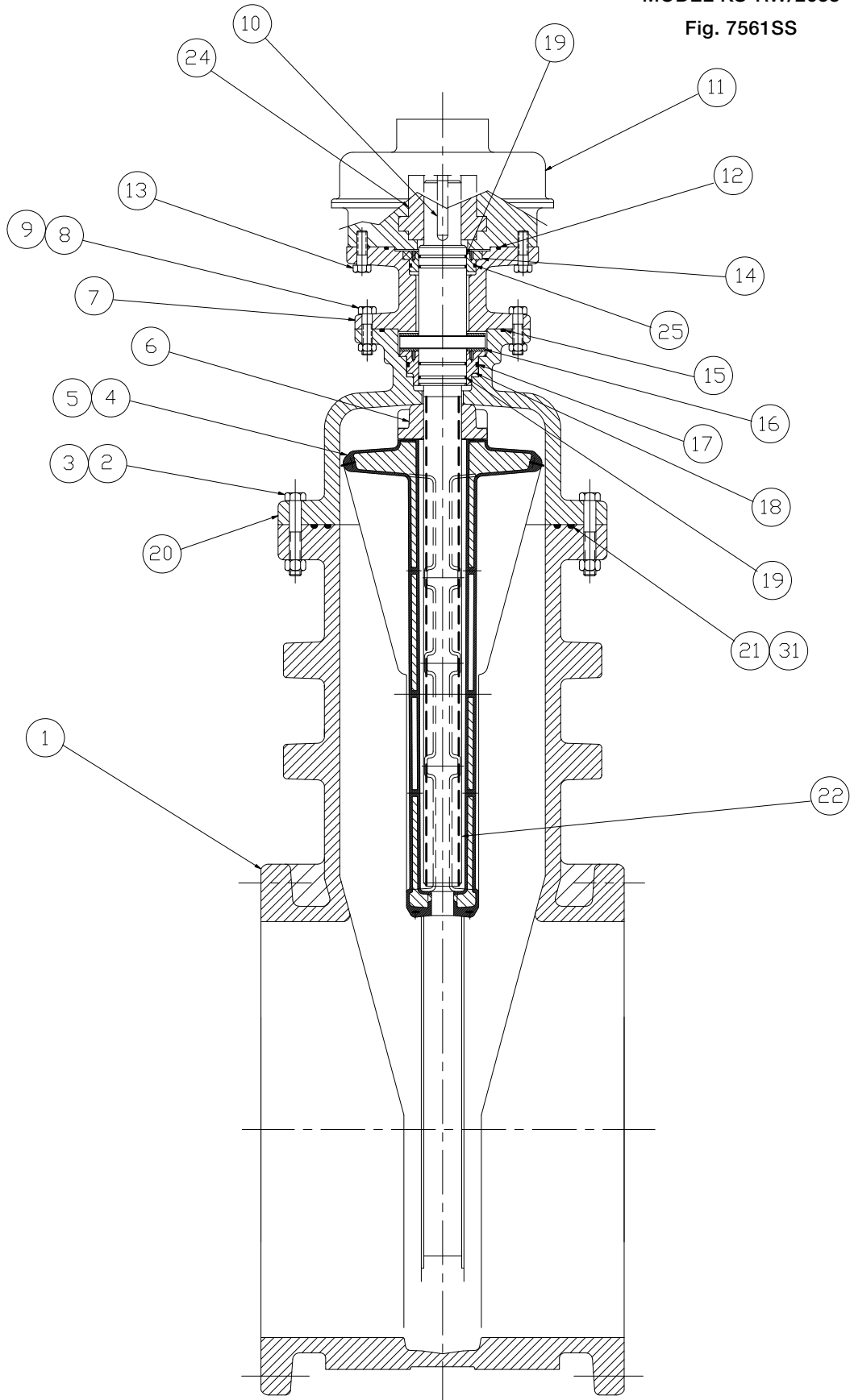

**30" - 54" RW VALVE
BEVEL GEAR ASSEMBLY**

KENNEDY VALVE

MODEL KS-RW/2638

Fig. 7561SS

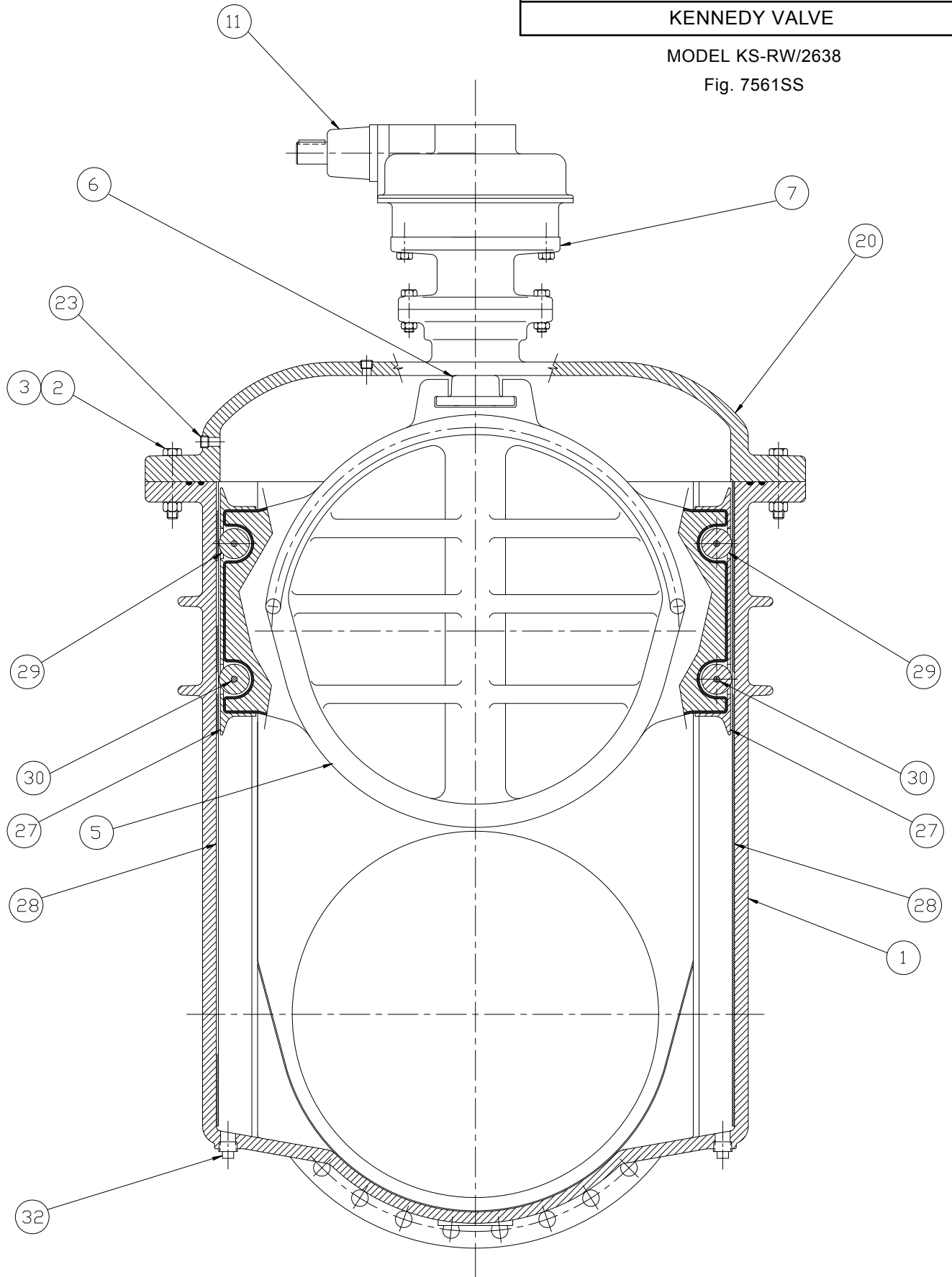

**30" - 54" R/W VALVE
BEVEL GEAR PARTS LIST**

KENNEDY VALVE

MODEL KS-RW/2638

Fig. 7561BMSS

ITEM	DESCRIPTION	MATERIAL
1	BODY - MECHANICAL JOINT	ASTM A536 DUCTILE IRON
	BODY - FLANGE	ASTM A536 DUCTILE IRON
	BODY - MJ X FLANGE	ASTM A536 DUCTILE IRON
2	BOLT	AISI 304 STAINLESS STEEL
3	NUT	AISI 304 STAINLESS STEEL
4	WEDGE CASTING	ASTM A536 DUCTILE IRON
5	MOLDED WEDGE	EPDM
6	STEM NUT	ASTM B763 ALLOY C87610 BRONZE
7	EXTENSION - ACTUATOR	ASTM B536 DUCTILE IRON
8	BOLT	AISI 304 STAINLESS STEEL
9	NUT	AISI 304 STAINLESS STEEL
10	KEY	STEEL
11	ACTUATOR - BEVEL GEAR	
12	O-RING	EPDM
13	BOLT	AISI 304 STAINLESS STEEL
14	BUSHING - STEM GUIDE	ASTM B584 ALLOY C83600 BRONZE
15	O-RING	EPDM
16	THRUST BEARING	NYLATRON
17	O-RING	EPDM
18	COVER BUSHING	ASTMB584 ALLOY C83600 BRONZE
19	O-RING	EPDM
20	COVER	ASTM B536 DUCTILE IRON
21	O-RING COVER OUTER	EPDM
22	STEM	ASTM B584 ALLOY C86200 BRONZE
23	PIPE PLUG	AISI 304 STAINLESS STEEL
24	ACTUATOR DRIVE BUSHING	BRONZE
25	O-RING	EPDM
26	WEDGE PROTECTOR	URETHANE
27	SCRAPER	ASTM B148 C95400 ALUMINUM BRONZE
28	TRACK	AISI 316 STAINLESS STEEL
29	ROLLER	ASTMB148 C95400 ALUMINUM BRONZE
30	PIN - ROLLER	AISI 316 STAINLESS STEEL
31	O-RING - COVER INNER	EPDM
32	PIPE PLUG	AISI 316 STAINLESS STEEL

**30" - 54" RW VALVE
SPUR GEAR ASSEMBLY**

KENNEDY VALVE

MODEL KS-RW/2638

Fig. 7561AMSS

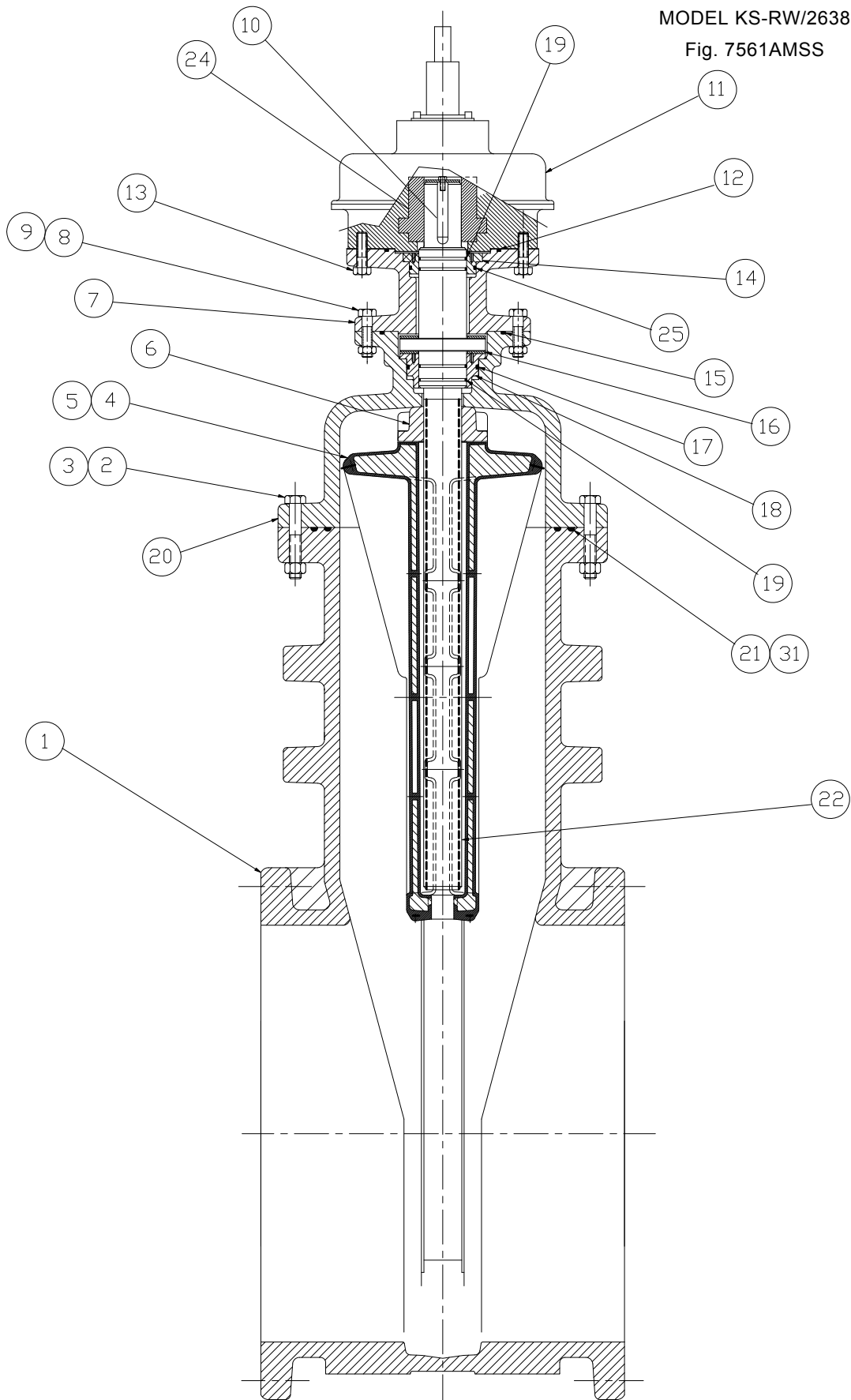

**30" - 54" R/W VALVE
SPUR GEAR ASSEMBLY**

KENNEDY VALVE

MODEL KS-RW/2638

Fig. 7561AMSS

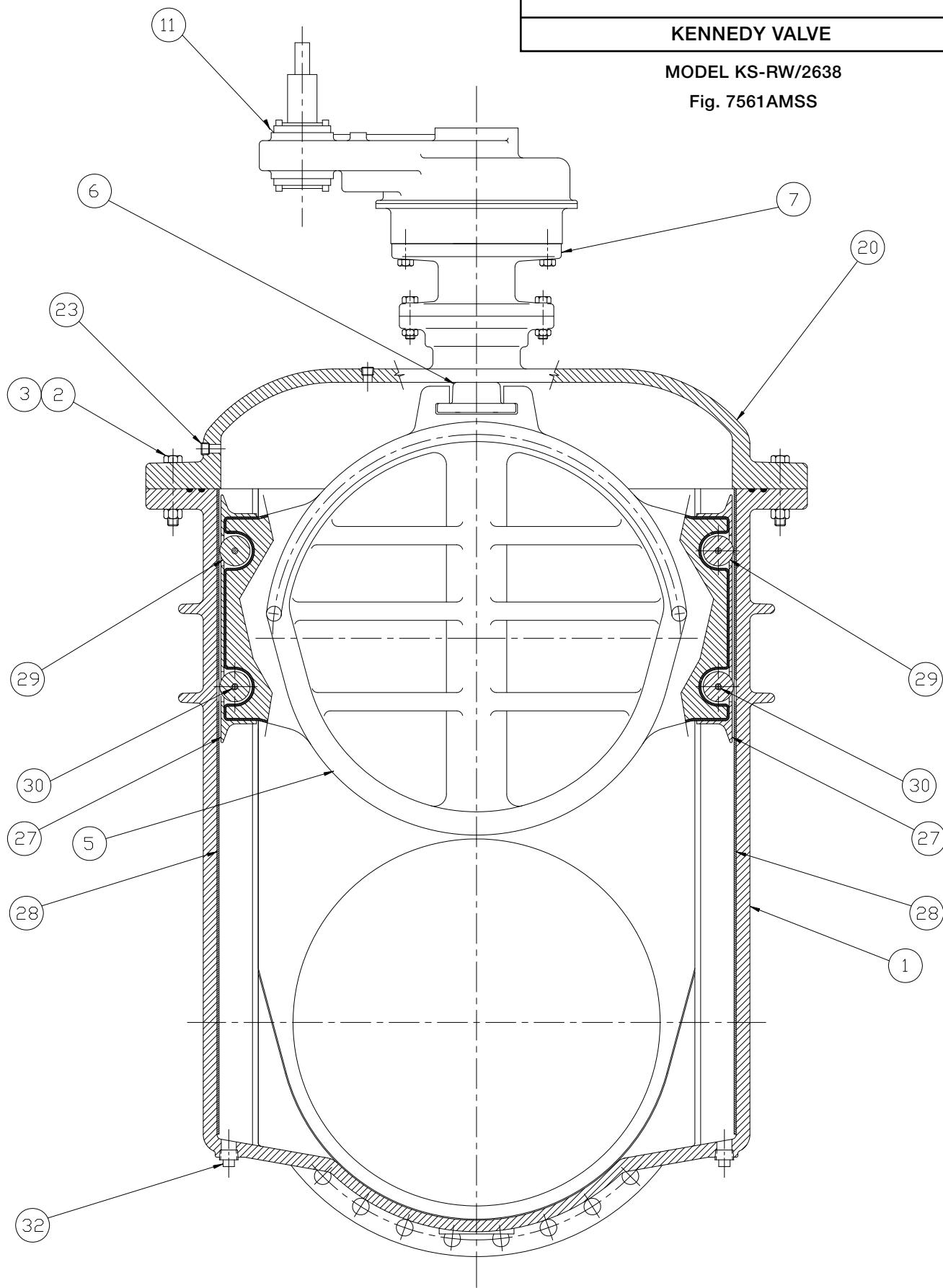

**30" - 54" R/W VALVE
SPUR GEAR PARTS LIST**

KENNEDY VALVE

MODEL KS-RW/2638

Fig. 7561AMSS

ITEM	DESCRIPTION	MATERIAL
1	BODY - MECHANICAL JOINT	ASTM A536 DUCTILE IRON
	BODY - FLANGE	ASTM A536 DUCTILE IRON
	BODY - MJ X FLANGE	ASTM A536 DUCTILE IRON
2	BOLT	AISI 304 STAINLESS STEEL
3	NUT	AISI 304 STAINLESS STEEL
4	WEDGE CASTING	ASTM A536 DUCTILE IRON
5	MOLDED WEDGE	EPDM
6	STEM NUT	ASTM B763 ALLOY C87610 BRONZE
7	EXTENSION - ACTUATOR	ASTM B536 DUCTILE IRON
8	BOLT	AISI 304 STAINLESS STEEL
9	NUT	AISI 304 STAINLESS STEEL
10	KEY	STEEL
11	ACTUATOR - SPUR GEAR	
12	O-RING	EPDM
13	BOLT	AISI 304 STAINLESS STEEL
14	BUSHING - STEM GUIDE	ASTM B584 ALLOY C83600 BRONZE
15	O-RING	EPDM
16	THRUST BEARING	NYLATRON
17	O-RING	EPDM
18	COVER BUSHING	ASTMB584 ALLOY C83600 BRONZE
19	O-RING	EPDM
20	COVER	ASTM B536 DUCTILE IRON
21	O-RING COVER OUTER	EPDM
22	STEM	ASTM B584 ALLOY C86200 BRONZE
23	PIPE PLUG	AISI 304 STAINLESS STEEL
24	ACTUATOR DRIVE BUSHING	BRONZE
25	O-RING	EPDM
26	WEDGE PROTECTOR	URETHANE
27	SCRAPER	ASTM B148 C95400 ALUMINUM BRONZE
28	TRACK	AISI 316 STAINLESS STEEL
29	ROLLER	ASTMB148 C95400 ALUMINUM BRONZE
30	PIN - ROLLER	AISI 316 STAINLESS STEEL
31	O-RING - COVER INNER	EPDM
32	PIPE PLUG	AISI 316 STAINLESS STEEL

30" - 54" R/W VALVE FLANGED ENDS BEVEL GEAR GENERAL DIMENSIONS

KENNEDY VALVE

MODEL KS-RW/2638

Fig. 7561BMSS

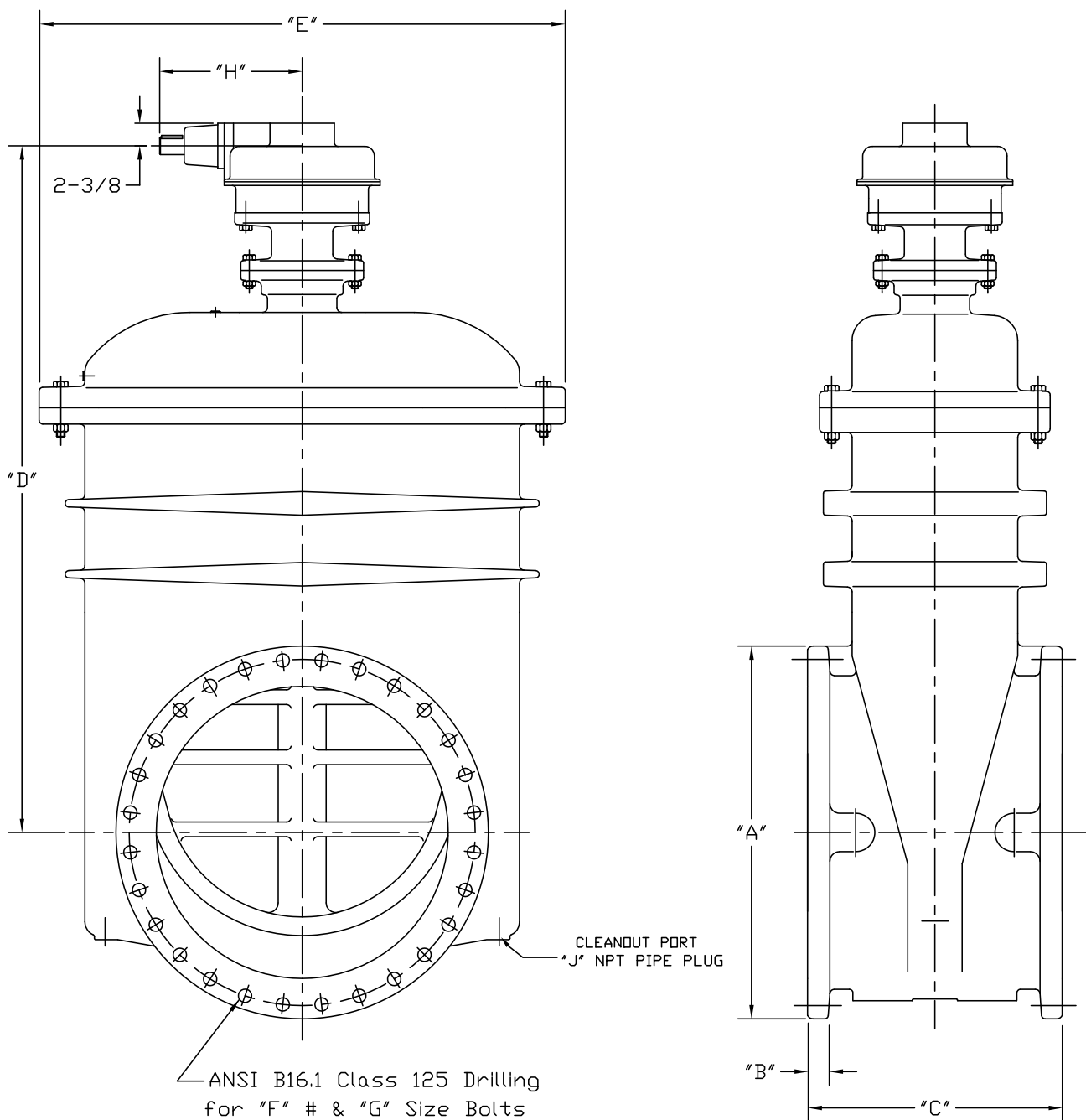

Valve Size	"A"	"B"	"C"	"D"	"E"	"F"	"G"	"H"	"J"
30"	38-3/4	2-1/8	26-1/2	71-1/2	54-3/4	28	1-1/4	14-7/8	2
36"	46	2-3/8	30-3/4	81-1/16	58-7/8	32	1-1/2	14-7/8	1-1/4
42"	53	2-5/8	36	98-3/8	78	36	1-1/2	17	1-1/2
48"	59-1/2	2-3/4	35-1/2	101-3/8	78	44	1-1/2	17	1-1/2
54"	66-1/4	3	48	101-3/8	78	44	1-3/4	17	1-1/2

**30" - 48" R/W VALVE MECH. JOINT ENDS
BEVEL GEAR GENERAL DIMENSIONS**

KENNEDY VALVE

MODEL KS-RW/2638

Fig. 7571BMSS

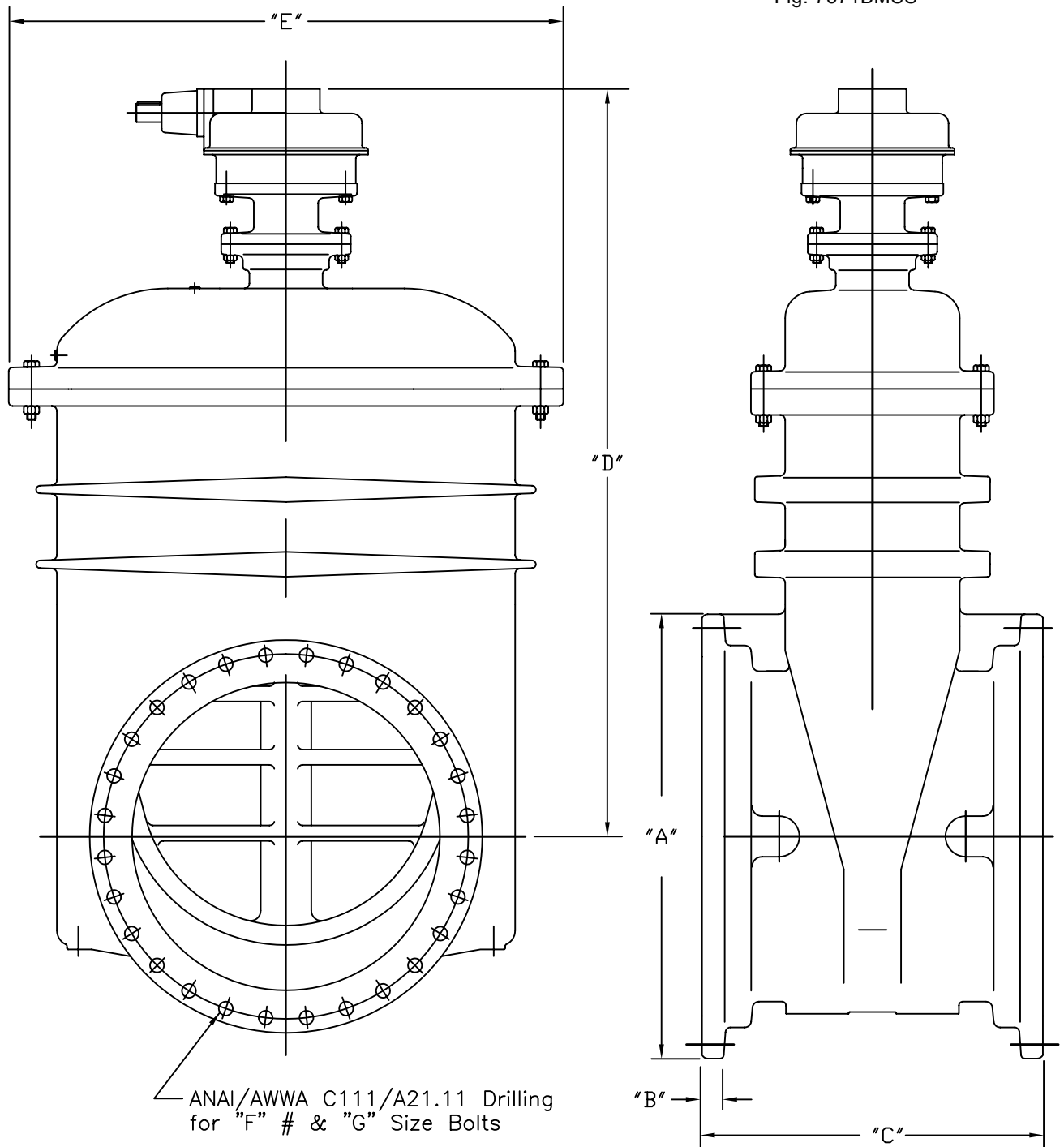

VALVE SIZE	A	B	C	D	E	F	G	H
30"	39 1/2	1 11/16	35 1/2	73 3/4	54 3/4	20	1	14 7/8
36"	46 1/2	2	38 3/4	81 1/16	58 7/8	24	1	14 7/8
42"	54	2	39	98 3/8	78	28	1 1/4	14 7/8
48"	60 3/4	2	44	101 3/8	78	32	1 1/4	14 7/8

**30" - 48" R/W VALVE MJ x FLG ENDS
BEVEL GEAR GENERAL DIMENSIONS**

KENNEDY VALVE

MODEL KS-RW/2638

Fig. 7572BMSS

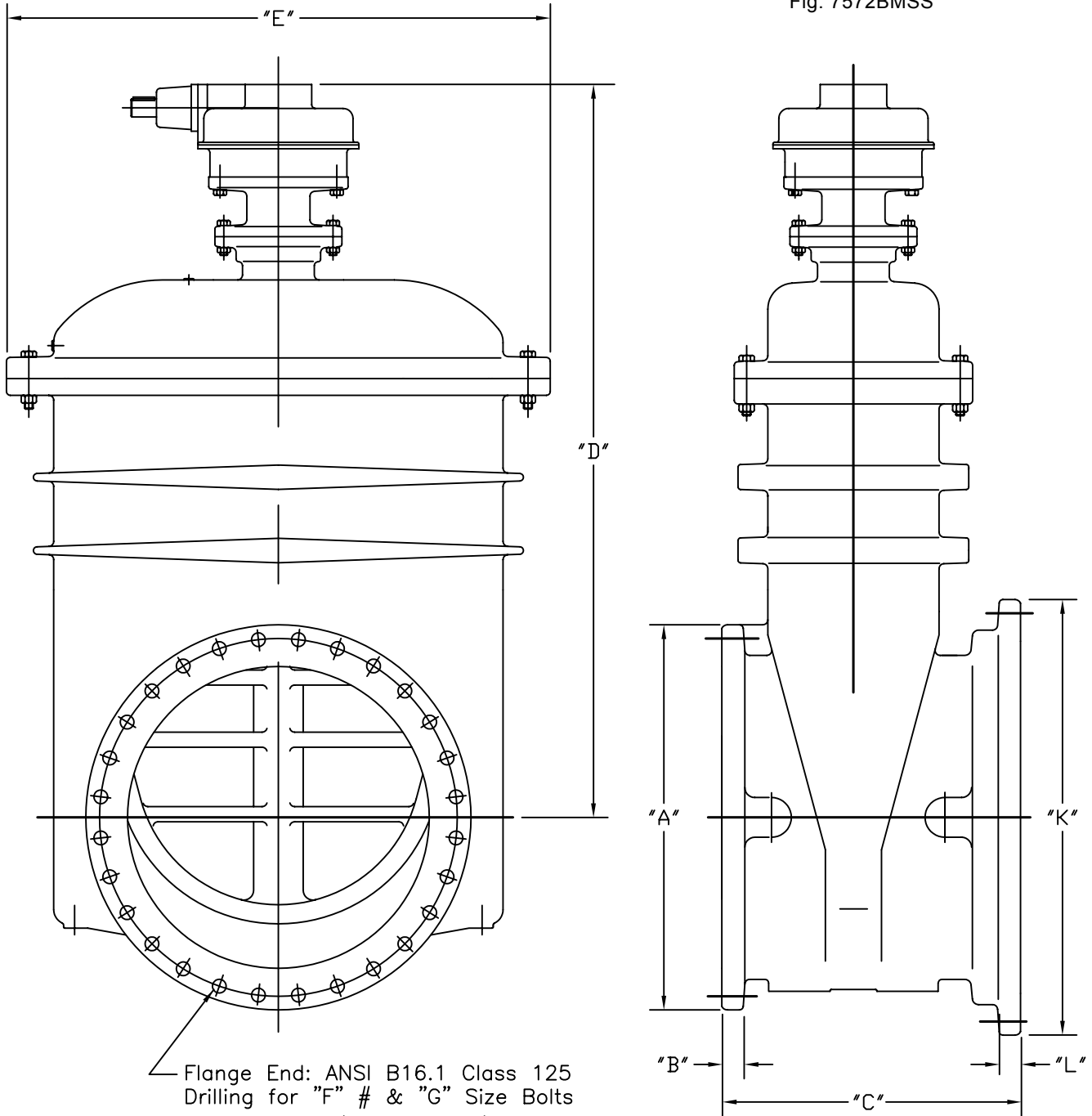

Flange End: ANSI B16.1 Class 125
Drilling for "F" # & "G" Size Bolts
MJ End: ANSI/AWWA C111/A21.11
Drilling for "H" # & "J" Size Bolts

VALVE SIZE	A	B	C	D	E	F	G	H	J	K	L	M
30"	38 3/4	2 1/8	31	73 3/4	54 3/4	28	1 1/4	20	1	39 1/2	1 11/16	14 7/8
36"	46	2 3/8	34 3/4	81 1/16	58 7/8	32	1 1/2	24	1	46 1/2	2	14 7/8
42"	53	2 5/8	37 1/2	98 3/8	78	36	1 5/8	25	1 3/8	54	2	14 7/8
48"	59 1/2	2 3/4	39	101 3/8	78	44	1 5/8	32	1 3/8	60 3/4	2	14 7/8

30" - 54" R/W VALVE FLANGED ENDS SPUR GEAR GENERAL DIMENSIONS

KENNEDY VALVE

MODEL KS-RW/2638

Fig. 7561AMSS

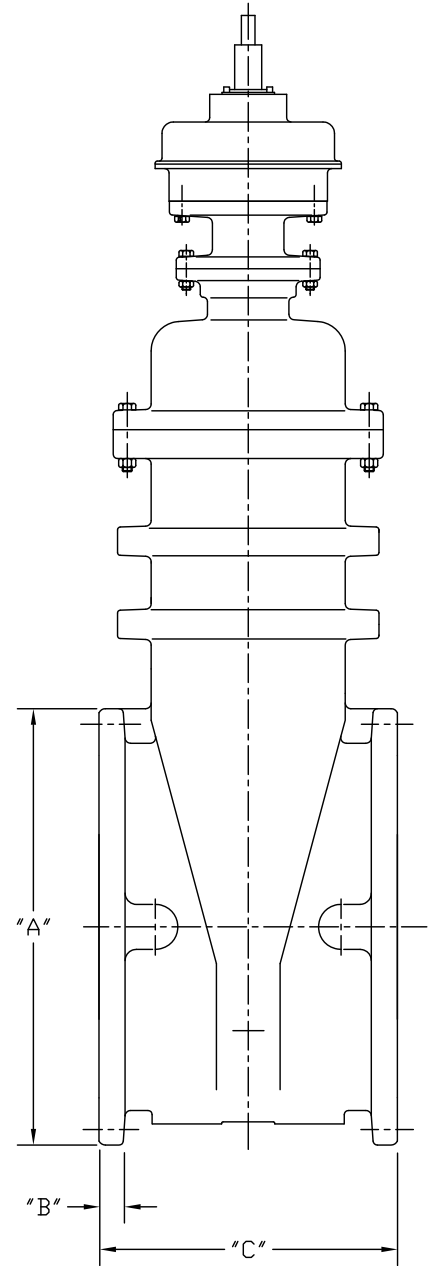
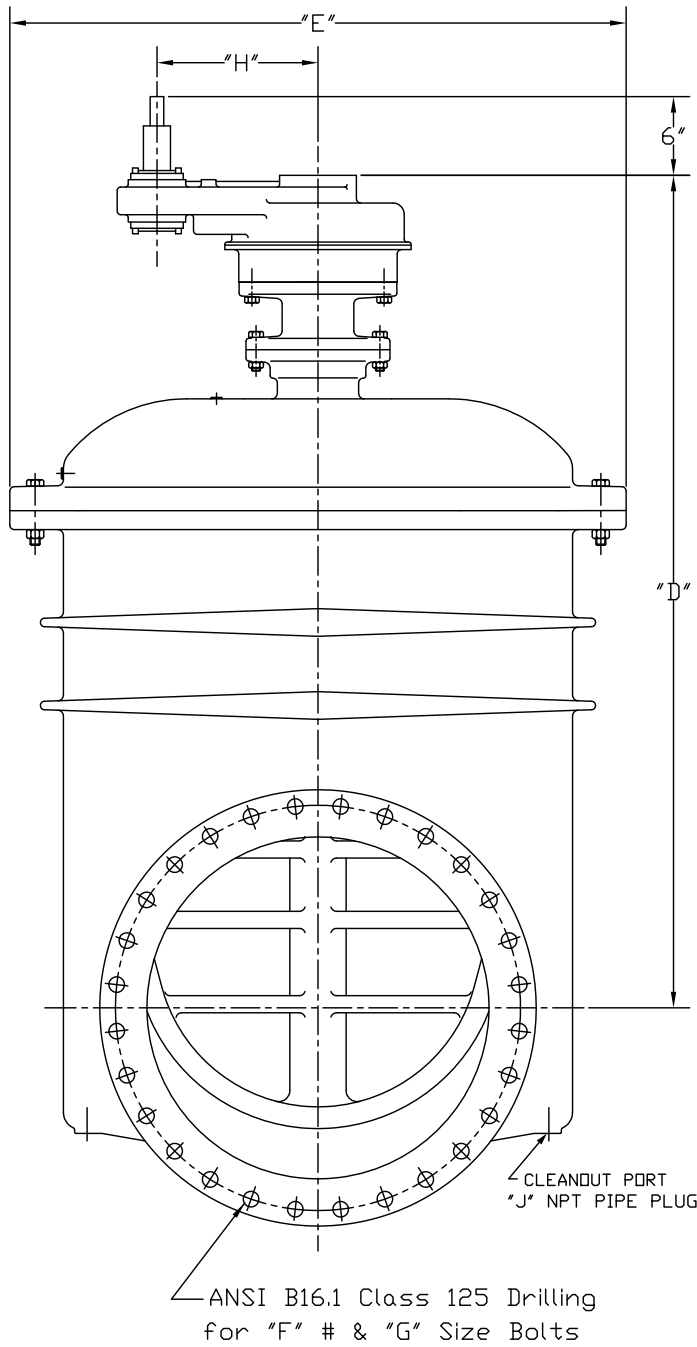

Valve Size	"A"	"B"	"C"	"D"	"E"	"F"	"G"	"H"	"J"
30"	38-3/4	2-1/8	26-1/2	74-1/8	54-3/4	28	1-1/4	14	2
36"	46	2-3/8	30-3/4	83-11/16	58-7/8	32	1-1/2	14	1-1/4
42"	53	2-5/8	36	102-1/2	78	36	1-1/2	16	1-1/2
48"	59-1/2	2-3/4	35-1/2	105-1/2	78	44	1-1/2	16	1-1/2
54"	66-1/4	3	48	105-1/2	78	44	1-3/4	16	1-1/2

**30" - 48" RW VALVE MECH. JOINT ENDS
SPUR GEAR GENERAL DIMENSIONS**

KENNEDY VALVE

MODEL KS-RW/2638

Fig. 7571AMSS

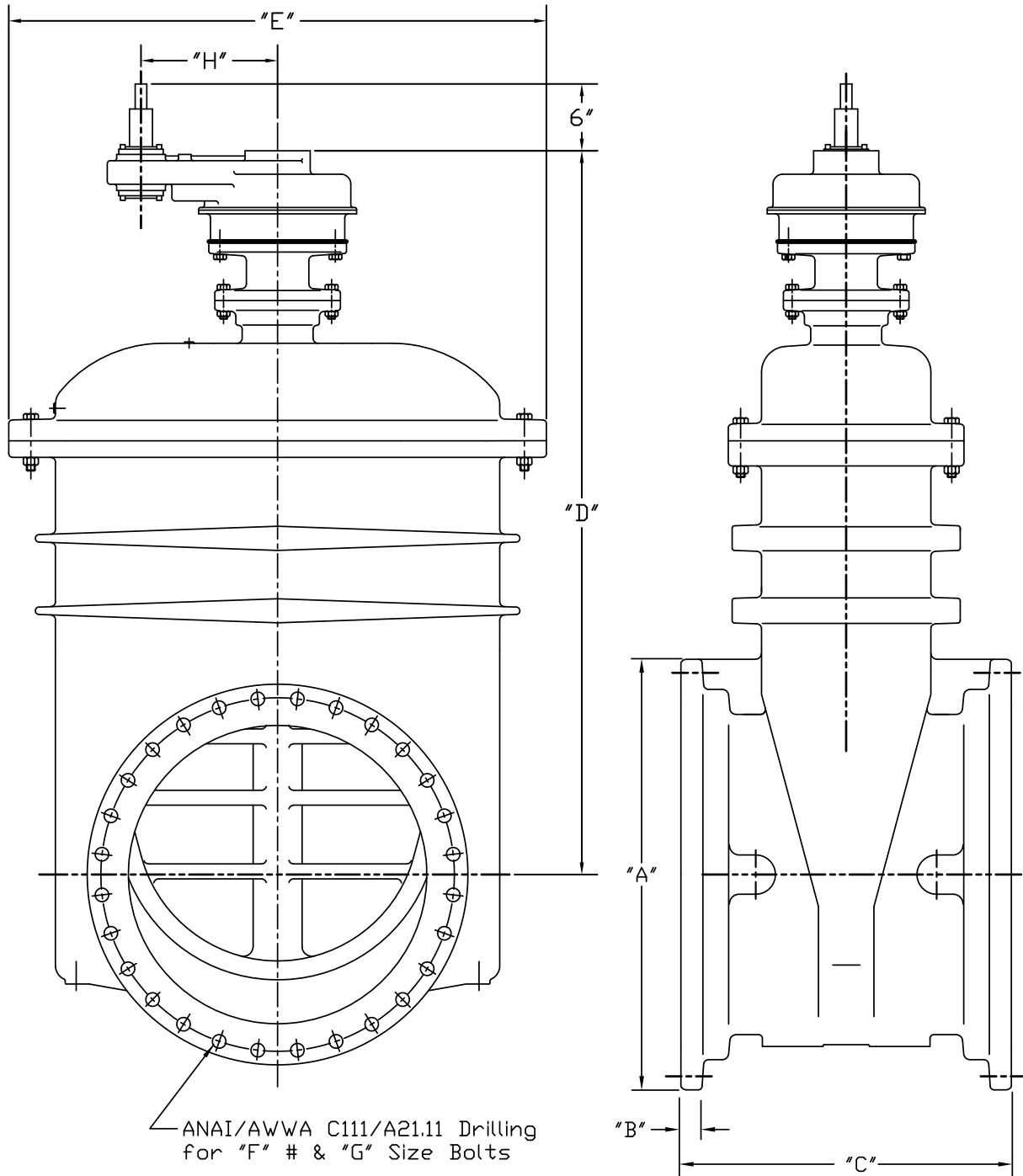

VALVE SIZE	A	B	C	D	E	F	G	H
30"	39 1/2	1 11/16	35 1/2	74	54 3/4	20	1	14
36"	46 1/2	2	38 3/4	83 11/16	58 7/8	24	1	14
42"	54	2	39	102 1/2	78	28	1 1/4	14
48"	60 3/4	2	44	105 1/2	78	32	1 1/4	14

30" - 48" R/W VALVE MJ x FLG ENDS SPUR GEAR GENERAL DIMENSIONS

KENNEDY VALVE

MODEL KS-RW/2638

Fig. 7572AMSS

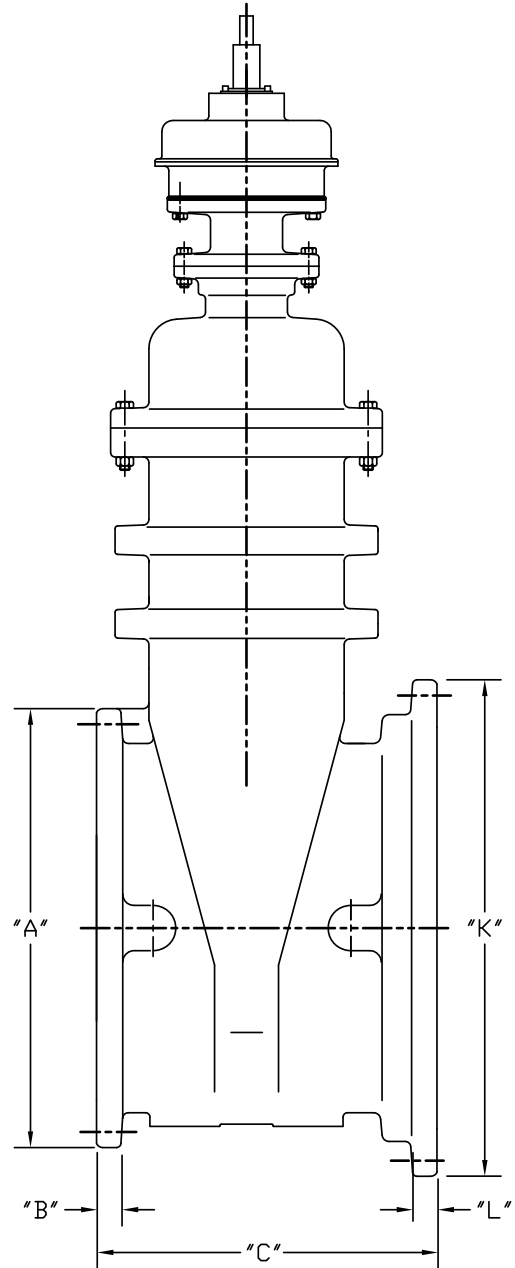
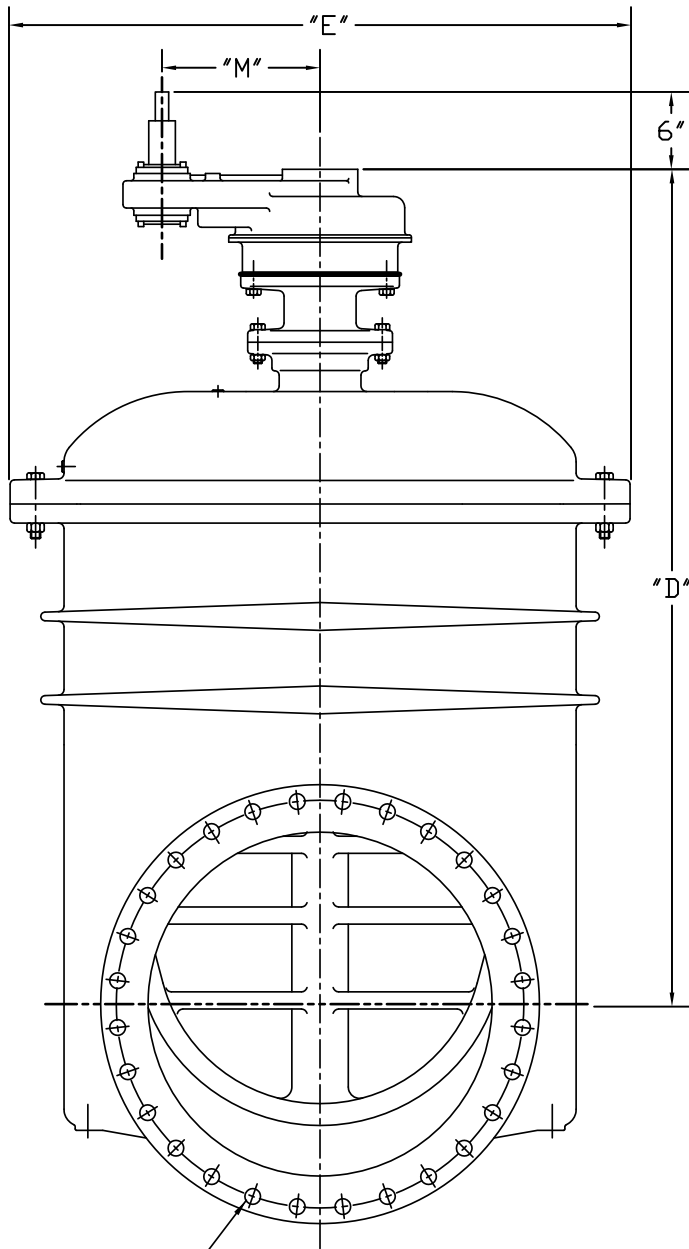

Flange End: ANSI B16.1 Class 125
Drilling for "F" # & "G" Size Bolts
MJ End: ANSI/AWWA C111/A21.11
Drilling for "H" # & "J" Size Bolts

VALVE SIZE	A	B	C	D	E	F	G	H	J	K	L	M
30"	38 3/4	2 1/8	31	74	54 3/4	28	1 1/4	20	1	39 1/2	1 11/16	14
36"	46	2 3/8	34 3/4	81 11/16	58 7/8	32	1 1/2	24	1	46 1/2	2	14
42"	53	2 5/8	37 1/2	102 1/2	78	36	1 5/8	25	1 3/8	54	2	14
48"	59 1/2	2 3/4	39	105 1/2	78	44	1 5/8	32	1 3/8	60 3/4	2	14

30" - 48" R/W VALVE FLANGED ENDS BEVEL GEAR BYPASS GENERAL DIMENSIONS

KENNEDY VALVE

MODEL KS-RW/2638

Fig. 7561BEMSS

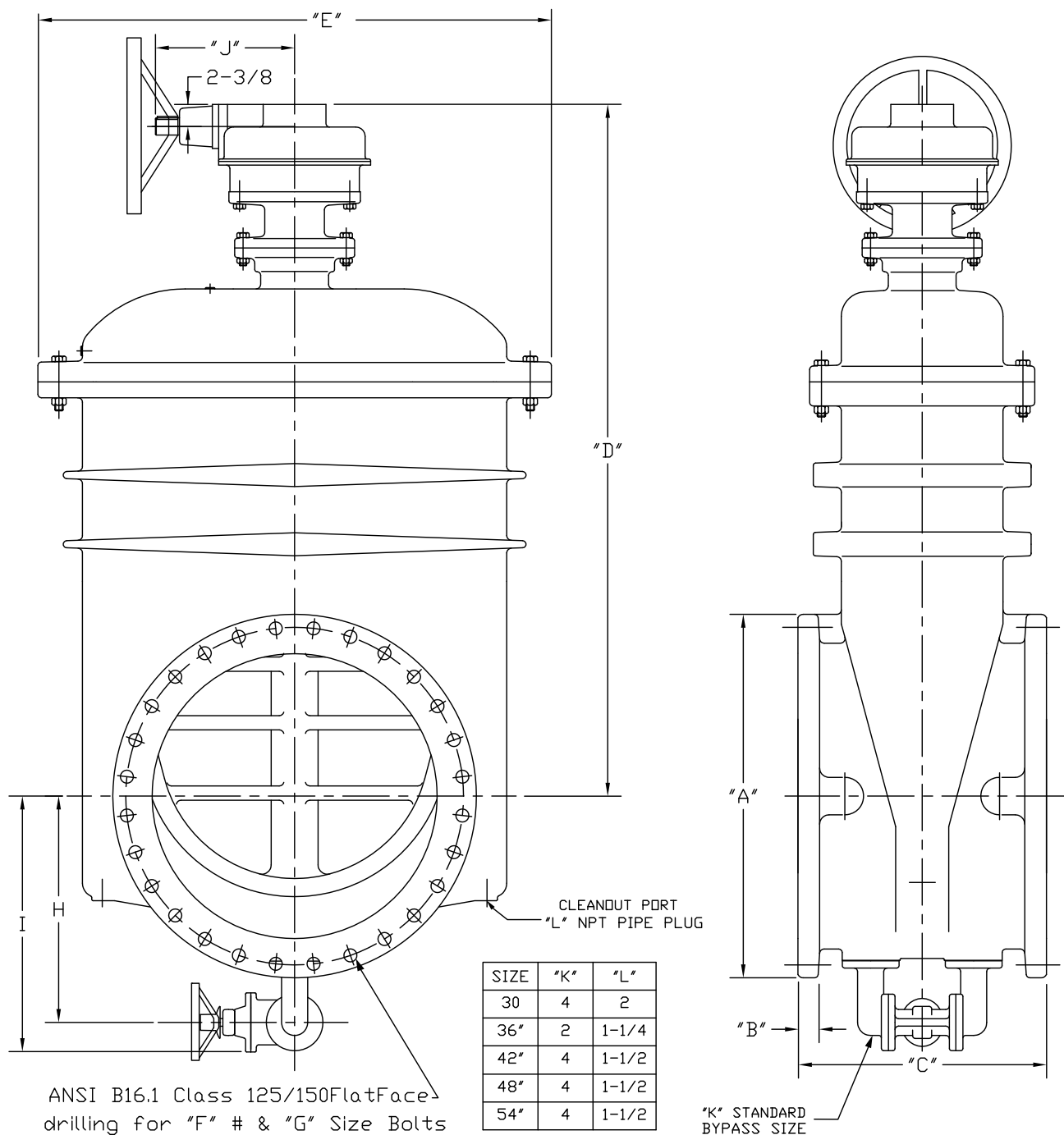

Valve Size	"A"	"B"	"C"	"D"	"E"	"F"	"G"	"H"	"I"	"J"
30"	38-3/4	2-1/8	26-1/2	73-7/8	54-3/4	28	1-1/4	24	28-1/2	14-7/8
36"	46	2-3/8	30-3/4	83-7/16	58-7/8	32	1-1/2	27-1/4	30-1/4	14-7/8
42"	53	2-5/8	36	100-3/4	78	36	1-1/2	30-15/16	35-7/16	17
48"	59-1/2	2-3/4	35-1/2	103-3/4	78	44	1-1/2	33-15/16	38-7/16	17
54"	66-1/4	3	48	103-3/4	78	44	1-3/4	37-5/16	41-13/16	17

**30" - 48" R/W VALVE MJ ENDS BEVEL
GEAR BYPASS GENERAL DIMENSIONS**

KENNEDY VALVE

MODEL KS-RW/2638

Fig. 7571BEMSS

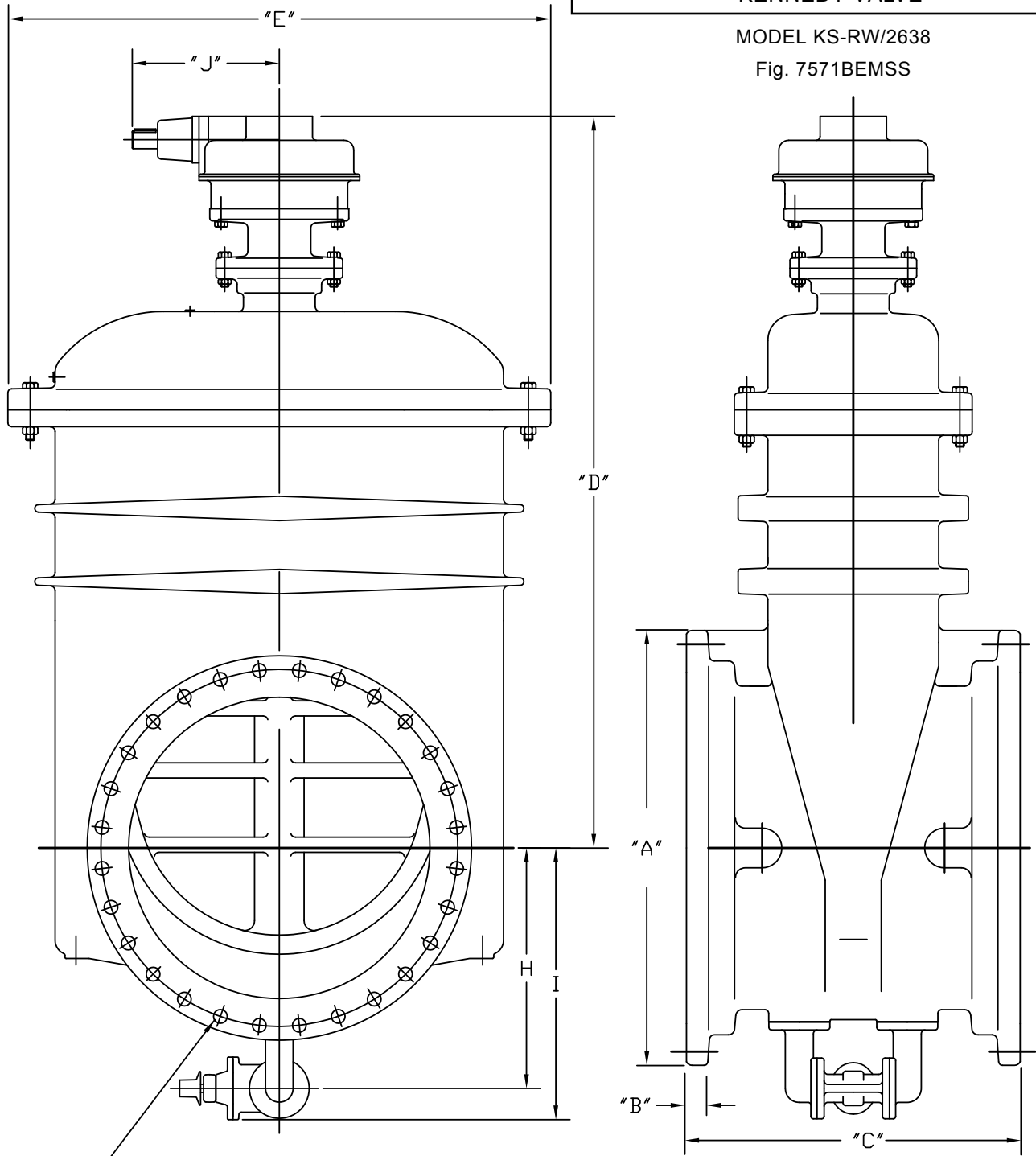

— ANAI/AWWA C111/A21.11 Drilling
for "F" # & "G" Size Bolts

VALVE SIZE	A	B	C	D	E	F	G	H	I	J
30"	39 1/2	1 11/16	35 1/2	73 3/4	54 3/4	20	1	24	27	14 7/8
36"	46 1/2	2	38 3/4	83 7/16	58 7/8	24	1	27 1/4	30 1/4	14 7/8
42"	54	2	39	100 3/4	78	28	1 1/4	30 15/16	35 7/16	14 7/8
48"	60 3/4	2 1/8	44	103 3/4	78	32	1 1/4	33 15/16	38 7/16	14 7/8

**30" - 48" RW VALVE MJ x FLG ENDS BEVEL
GEAR BYPASS GENERAL DIMENSIONS**

KENNEDY VALVE

MODEL KS-RW/2638

Fig. 7572BEMSS

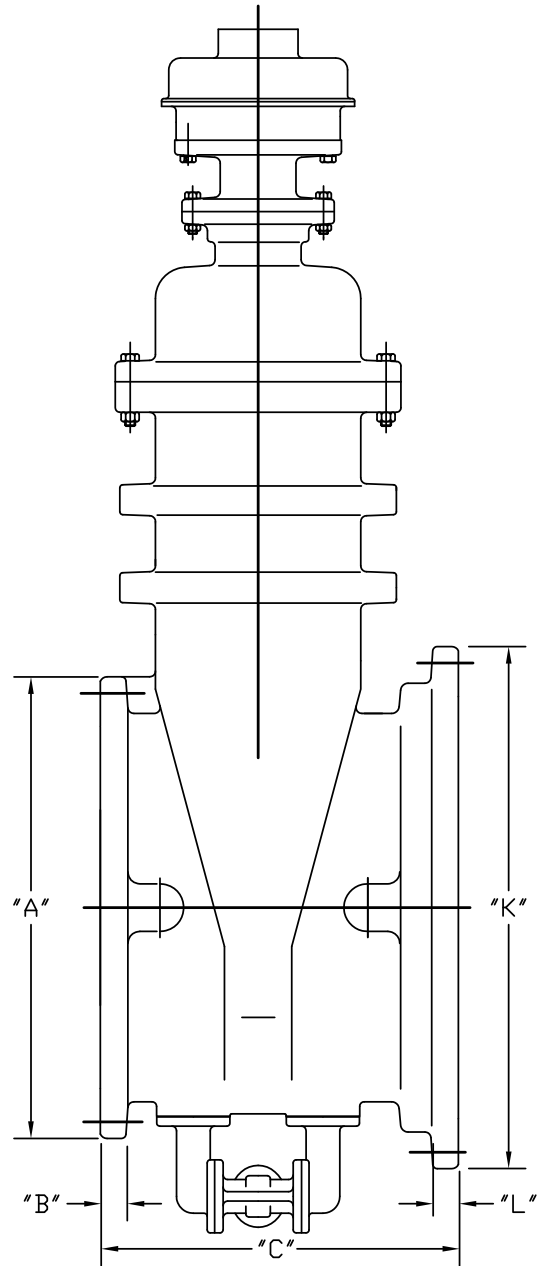
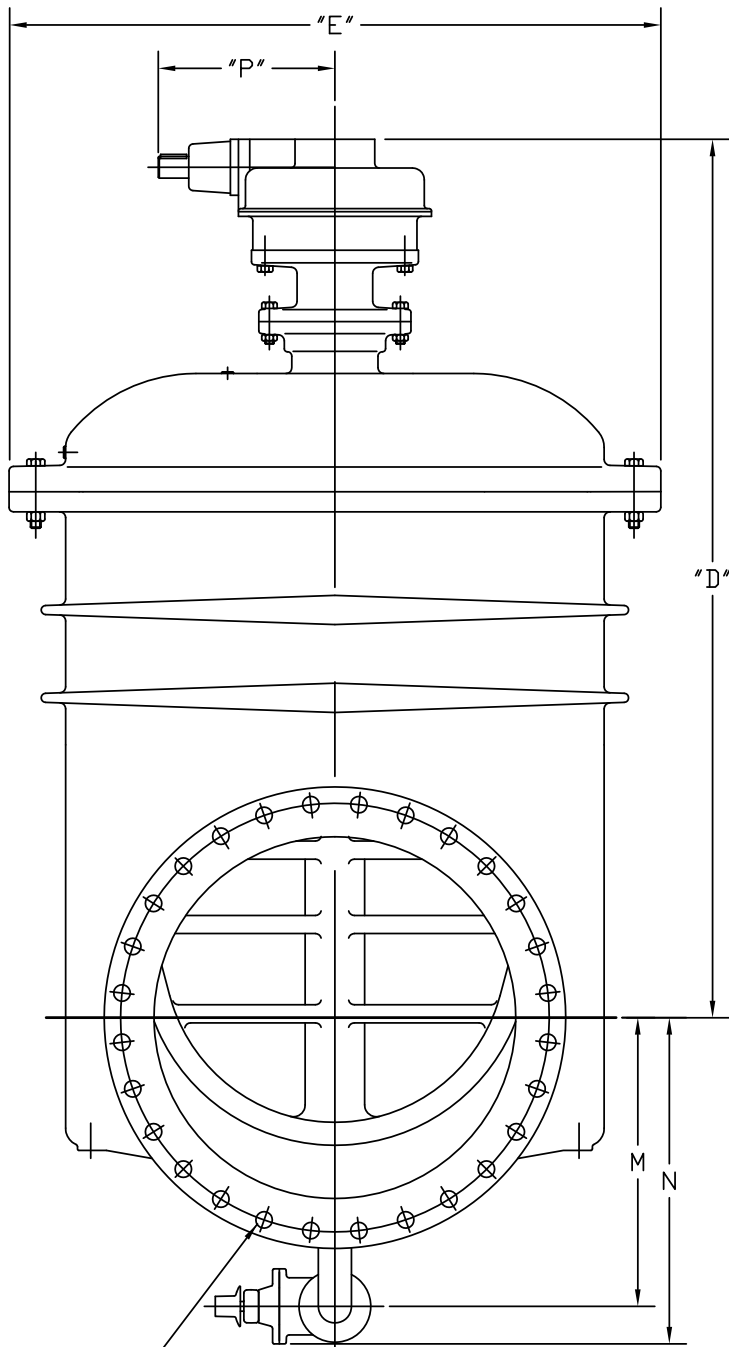

Flange End: ANSI B16.1 Class 125
Drilling for "F" # & "G" Size Bolts
MJ End: ANSI/AWWA C111/A21.11
Drilling for "H" # & "J" Size Bolts

VALVE SIZE	A	B	C	D	E	F	G	H	J	K	L	M	N	P
30"	38 3/4	2 1/8	31	73 3/4	54 3/4	28	1 1/4	20	1	39 1/2	1 11/16	24	27	14 7/8
36"	46	2 3/8	34 3/4	83 7/16	58 7/8	32	1 1/2	24	1	46 1/2	2	27 1/4	30 1/4	14 7/8
42"	53	2 5/8	37 1/2	100 3/4	78	36	1 5/8	28	1 3/8	54	2	30 15/16	35 7/16	14 7/8
48"	59 1/2	2 3/4	39	103 3/4	78	44	1 5/8	32	1 3/8	60 3/4	2	33 15/16	38 7/16	14 7/8

**30" - 48" R/W VALVE BEVEL GEAR
ASSEMBLY WITH BYPASS**

KENNEDY VALVE

MODEL KS-RW/2638

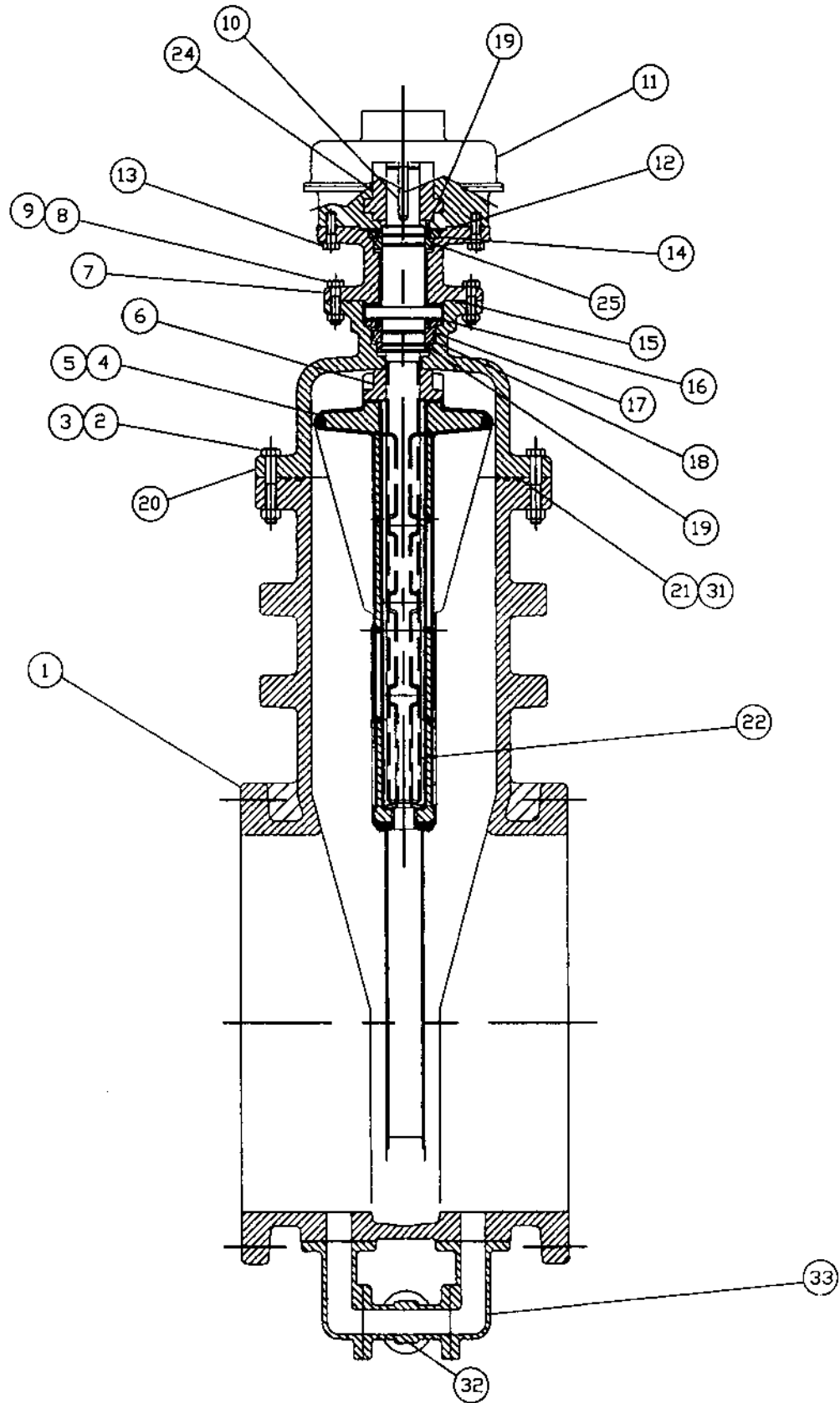

**30" - 48" R/W VALVE BEVEL
GEAR ASSEMBLY WITH BYPASS**

KENNEDY VALVE

MODEL KS-RW/2638

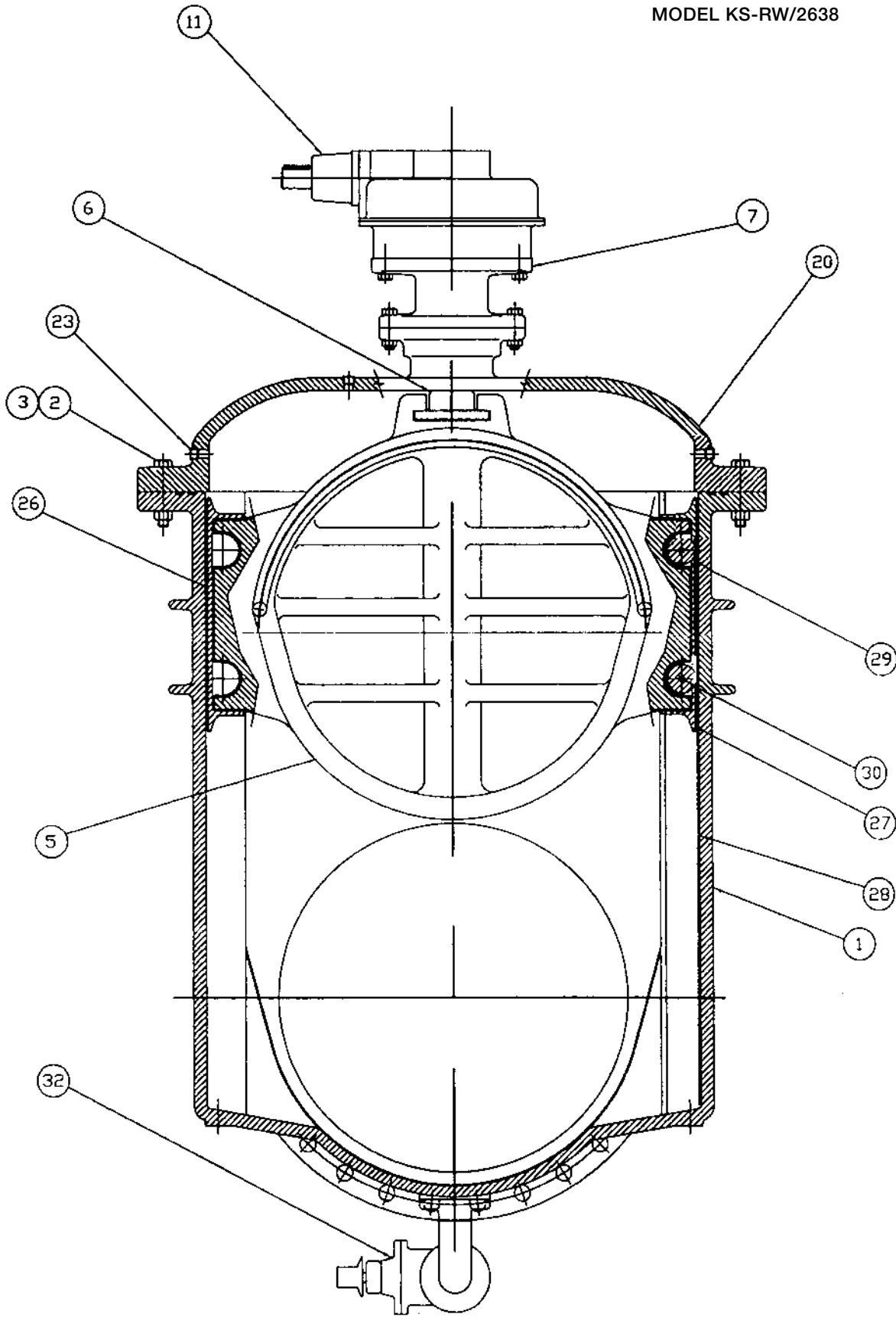

**30" - 48" R/W VALVE BEVEL GEAR
PARTS LIST WITH BYPASS**

KENNEDY VALVE

MODEL KS-RW/2638

ITEM	QTY	DESCRIPTION	MATERIAL
1	1	BODY - MECHANICAL JOINT	ASTMA536 DUCTILE IRON
		BODY - FLANGE	ASTMA536 DUCTILE IRON
		BODY - MJ X FLANGE	ASTMA536 DUCTILE IRON
		BODY - FASTITE	ASTMA536 DUCTILE IRON
2	22	BOLT - 7/8-9NC HEX HD X 5-1/2 LG	AISI304 STAINLESS STEEL
3	22	NUT - 7/8-9NC HEX	AISI304 STAINLESS STEEL
4	1	WEDGECASTING	ASTMA536 DUCTILE IRON
5	1	MOLDEDWEDGE	EPDM
6	1	STEMNUT	ASTM B763 ALLOY C87610 BRONZE
7	1	EXTENSION - ACTUATOR	ASTMB536 DUCTILE IRON
8	8	BOLT	AISI304 STAINLESS STEEL
9	8	NUT	AISI304 STAINLESS STEEL
10	1	KEY	STEEL
11	1	ACTUATOR	
12	1	O-RING	EPDM
13	8	BOLT	AISI304 STAINLESS STEEL
14	1	BUSHING - STEM GUIDE	ASTM B584 ALLOY C83600 BRONZE
15	1	O-RING	BUNA-N RUBBER
16	2	THRUSTBEARING	NYLATRON
17	1	O-RING	EPDM
18	1	COVER BUSHING	ASTMB584 ALLOY C83600 BRONZE
19	4	O-RING	EPDM
20	1	COVER	ASTMB536 DUCTILE IRON
21	1	O-RING COVER OUTER	EPDM
22	1	STEM	ASTMB583 ALLOY C83600 BRONZE
23	2	PIPEPLUG- 3/4 NPT W/SQUARE HD	AISI 304 STAINLESS STEEL
24	1	ACTUATORDRIVE BUSHING	BRONZE
25	1	O-RING	EPDM
26	1	WEDGEPROTECTOR	URETHANE
27	1	SCRAPER	ASTMB148 C95400 ALUMINUM BRONZE
28	1	TRACK	AISI316 STAINLESS STEEL
29	2	ROLLER	ASTMB148 C95400 ALUMINUM BRONZE
30	2	PIN - ROLLER	AISI316 STAINLESS STEEL
31	1	O-RING - COVER INNER	EPDM
32	1	BYPASSVALVE	ASTMA536 DUCTILE IRON



Kennedy Valve

A DIVISION OF McWANE, INC.

www.kennedyvalve.com

1021 E. Water Street • Elmira, New York 14901
P.O. Box 981
PHONE: (607) 734-2211 • FAX: 1-800-952-4771

Updated 05/21/24