



**KENNEDY VALVE**

# GUARDIAN K81-D FIRE HYDRANT

## CERTIFICATIONS

ISO 9001

ISO 14001

BS OHSAS 18001



**AWWA C502  
NSF 61**



[WWW.KENNEDYVALVE.COM](http://WWW.KENNEDYVALVE.COM)



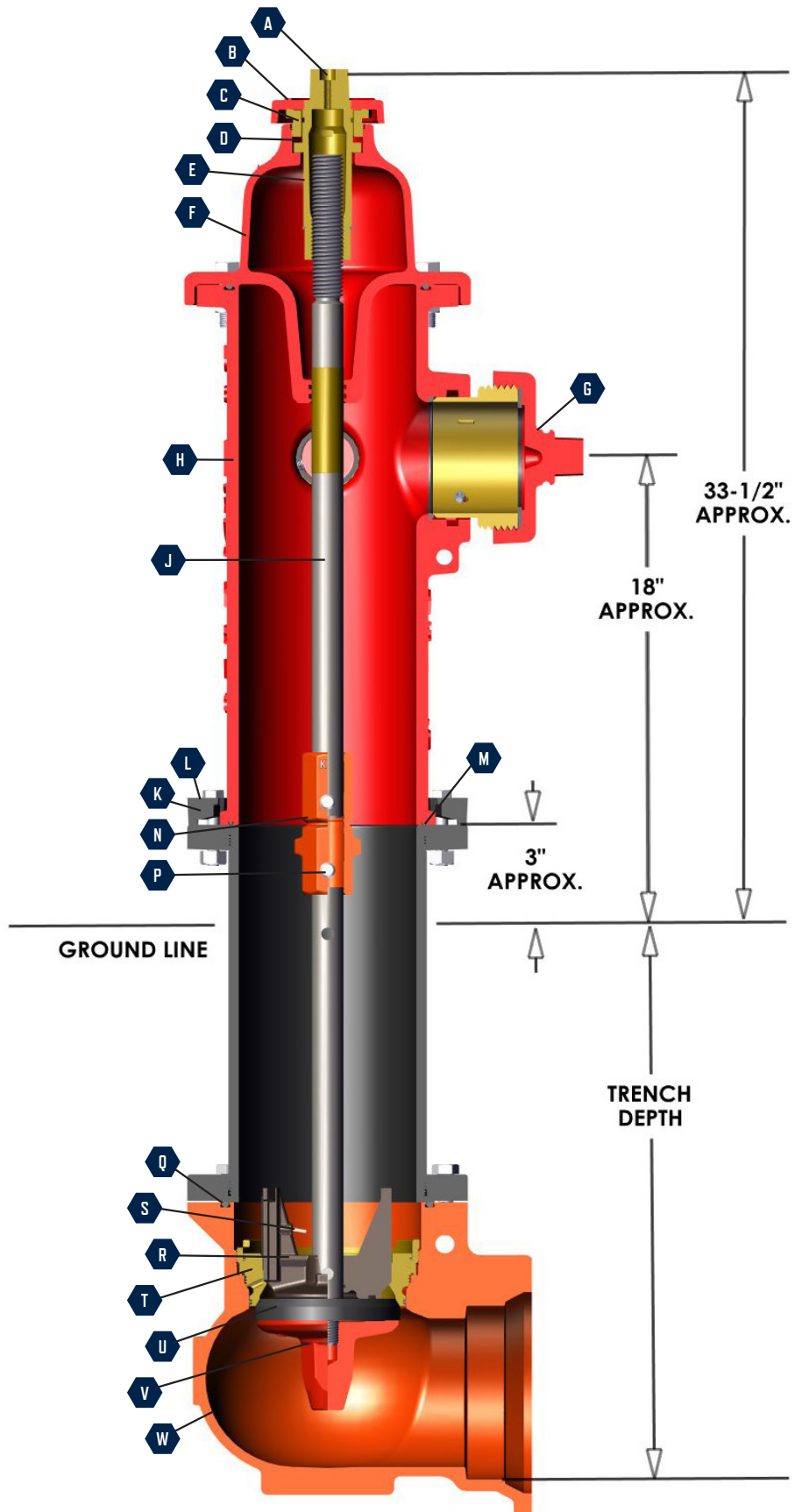

- A | ALEMITE FITTING**  
Recessed grease fitting provides convenient access to lubricate operating threads for corrosion protection.
- B | DIRT SHIELD**  
One-piece component deflects moisture and dust exposure. Affords protection against freezing conditions ensuring operational efficiency.
- C | STEM LOCK NUT**  
Corrosion-resistant bronze nut secures stem nut for operating thrust. Lock nut provides additional weather protection with threading attachment to hydrant cap and large o-ring seal.
- D | THRUST WASHER**  
Anti-friction bearing at thrust collar reduces operating torque for smoother open / close cycles.
- E | STEM NUT**  
Specially designed grease slots and part threads allow for constant lubrication to stem nut and stem.
- F | HYDRANT CAP / BONNET**  
Single unit design contains factory applied grease. Two o-ring seals at penetration point of operating stem prevent lubricant to escape and excludes water entry of chamber when hydrant is pressurized.
- G | HOSE / PUMPER NOZZLE**  
Tamper resistant quarter turn hose and steamer nozzles. Designed for ease of maintenance and field replacement.
- H | UPPER BARREL / NOZZLE SECTION**  
Available with either two hose and one pumper nozzle or two hose nozzles.
- J | UPPER STEM**  
High strength steel stem with an integral machined fitted, brass sleeve (ferrule) that penetrates the cap / bonnet, providing smooth, corrosion-resistant bearing surface for the double O-ring seals.
- K | BREAKING RING / TRAFFIC FLANGE**  
Breaking ring on top for ease of replacement. Upon vehicular impact, it fractures to allow above ground hydrant assembly to separate cleanly from standpipe without damage to internal parts or loss of water. Repair is easily accomplished with economical field repair kit. Also allows upper to have full 360° adjustment.
- L | BREAKING RING STRAP**  
Strap designed to help align hydrant upper to lower barrel during reassembly.
- M | BARREL O-RING**  
Creates positive seal between lower barrel and upper barrel.
- N | STEM BREAK COUPLING**  
Designed to break from collision without bending or damage to main valve or lower rod. Bottom half of coupling is designed to accept seat removal wrench.
- P | COUPLING PINS**  
Updated stainless steel pin design uses spring loaded pin. No need for clevis pins, nuts, or other securing device. No tools required.
- Q | ELBOW O-RING**  
Creates positive seal between lower barrel and hydrant elbow.
- R | DRAIN VALVE**  
After operation, the high strength Aluminum Bronze drain valve automatically drains all water from the barrel of the hydrant preventing cold weather freeze-up. Drain ports are purged during first three operating turns on opening and again on closing.
- S | DRAIN VALVE FACING with INSERT**  
Unique pressure activated drain valve assures positive shut off. The higher the pressure, the tighter the seal. Automatically compensates for wear due to usage. Does not rely on interference fit.
- T | ELBOW INSERT RING**  
Secured in elbow with O-ring seal. Provides bronze to bronze interface for easy seat removal.
- U | MAIN VALVE**  
EPDM material with steel insert to provide rigidity. Integral O-rings provide positive seal between bottom plate and stem.
- V | BOTTOM PLATE**  
One piece cast iron bottom plate securely attaches valve assembly to lower stem. Bottom plate is coated with fusion bonded epoxy and meets A.W.W.A. C550 standard.
- W | ELBOW**  
Fusion bonded epoxy coating inside and out. Meets AWWA C550 standards. 6" Mechanical Joint standard.

Kennedy Hydrants are designed for performance, serviceability, and outstanding longevity. Here's why experienced pros insist on Kennedy's advantages:

## **INTELLIGENTLY ENGINEERED for LONGER LIFE and FEWER WEAR PARTS**

Backed by over 100 years of hydrant design know-how, the K81-D has been carefully engineered for rugged durability and longer life. Extra seals to protect against corrosion. Reinforced rubber main valve and rugged drain valve assembly. Positive stop prevents unintentional damage from over torquing during opening.

## **EASIEST to MAINTAIN and SERVICE**

Fewer parts to disassemble and reassemble. Lubricated with grease instead of liquid oil; lubricant stays where it's needed and doesn't evaporate away or make a mess. Dove tail machining provides captive O-rings and breaker coupling spring loaded pins prevent lost parts. No special tools needed to remove / clean valve seat or remove drain valve. Higbee cut starter threads prevent cross-threading when reassembling valve into elbow. Quarter turn hose nozzles are positively retained and can be easily removed for maintenance.

## **BACKWARDS-COMPATIBLE DESIGN = JUST ONE SET of REPLACEMENT PARTS**

Whether it's a new unit or one that's an original K81 interchangeability means just one set of parts repairs them all. Simplify training, simplify maintenance, simplify inventories. Only a handful of recommended wear parts to stock.

## **FASTEST, EASIEST COLLISION RESTORATION**

Designed for a clean break, reducing fatigue or deformity to stem coupling or damage to barrel. U-slotted lower barrel upper flange allow bolts to escape without damage to flange. Breaker rings on-top for easy visual inspection and replacement. Quick, economical repairs with standard collision kit. Extension kits also install fast and easy.

- Hydrants shall be UL listed and FM approved.
- Hydrants shall conform to AWWA standard C502 latest revision.
- Hydrants shall be of the compression type, closing with line pressure.
- Hydrants shall be of the traffic model breakaway type.
- The combination of 3 O-rings to a crimped brass ferrule around stem shall seal the cavity from contact w/ water.
- An Alemite fitting shall be supplied for periodic lubrication of the operating threads with grease.
- Operating nut shall be of one piece bronze construction.
- A dirt shield shall be provided to protect the operating mechanism from grit buildup & corrosion due to moisture.
- A thrust washer shall be supplied between the operating nut and stem lock nut to facilitate operation.
- Nozzles shall be of the tamper resistant, ¼ turn type with O-ring seals and stainless steel retaining screws.
- An O-Ring shall be provided to seal between the upper and lower barrels.
- The main valve shall be of synthetic rubber reinforced with steel.
- The seat shall be of bronze ring threaded to a bronze insert in the hydrant shoe, with O-rings to seal the drain way and barrel from leakage of water in the shoe.
- Drain way shall be of bronze.
- Drain valve facing shall be synthetic rubber with a stainless steel retaining pin.
- Hydrant drain valve shall momentarily force flush with each operation.

## FLOW ANALYSIS

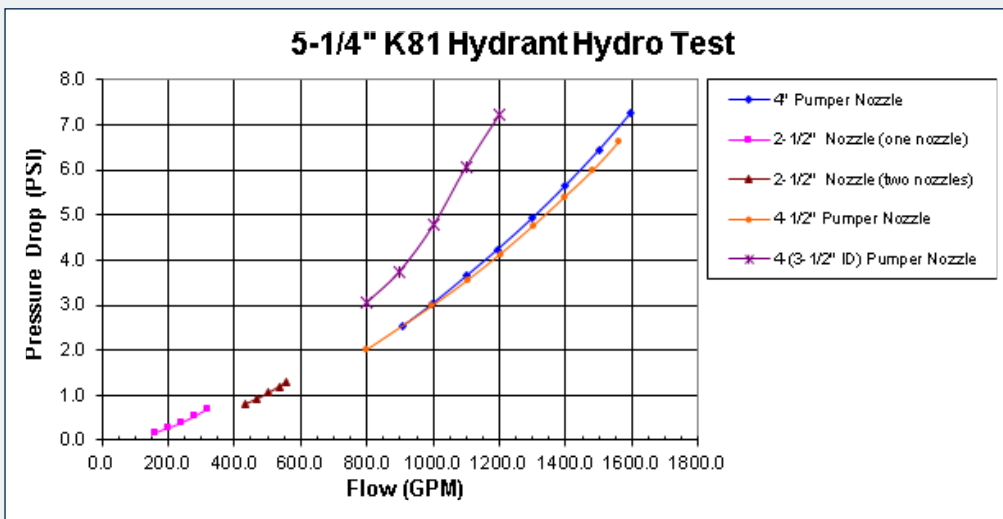

Superior flow with minimal pressure drop.

No. of Outlet Nozzles	Nominal Dia of Outlet Nozzles (in)	Total Flow from Nozzles (gpm)	AWWA C502 CV REQ	AWWA C502 KV (Metric) REQ	Kennedy Valve CV	Kennedy Valve KV
1	2-1/2"	250	250	216	379	327
2	2-1/2"	500	354	306	488	422
1	4" (3-1/2" ID)	1000	447	386	455	393
1	4" (3-1/2" ID)	1500	416	359	450	389
1	4"	1000	447	386	583	504
1	4"	1500	416	386	580	501
1	4-1/2"	1500	447	359	602	520
1	4-1/2"	1000	416	386	600	518

Multiple nozzle connections provide cities with numerous options.

CALLOUT	DESCRIPTION	MATERIAL ASTM
K8101	ALEMITE FITTING	STAINLESS STEEL, ASTM A276 (304)
K8102	OPERATING STEM NUT	BRONZE, ASTM B584 C83600/C84400
K8103	DIRT SHIELD	CAST IRON, ASTM A126, CLASS B
K8104	STEM LOCK NUT	BRONZE, ASTM B584 C83600/C84400
K8105	STEM LOCK NUT O-RING	VITON, ASTM D2000
K8106	THRUST WASHER	NYLATRON, GS MIL LP-410
K8107	HYDRANT CAP/BONNET	CAST IRON, ASTM A126, CLASS B
K8108	CAP BOLTS & NUTS	STEEL, (ZINC PLATED) ASTM A307/SAE GRADE 2
K8109	HYDRANT CAP O-RING	BUNA N, ASTM D2000
K8110	STEM FERRULE	BRASS, ASTM B135 C26000
K8111	HYDRANT CAP O-RING	BUNA N, ASTM D2000
K8114	UPPER STEM	COLD ROLLED STEEL, ASTM A108 C1018
K8115	UPPER BARREL/NOZZLE SECTION	CAST IRON, ASTM A126 CLASS B
K8116	STEM BREAK COUPLING	CAST IRON, ASTM A126, CLASS B
K8118	NUTS AND BOLTS	STEEL, (ZINC PLATED) ASTM A307/SAE GRADE 2
K8119	BREAKING RING/TRAFFIC FLANGE	CAST IRON, ASTM A126, CLASS B
K8120	O-RING	BUNA N, ASTM D2000
K8122R	COUPLING PIN	STAINLESS STEEL, 302 HQ
K8123	LOWER STEM	COLD ROLLED STEEL, ASTM A108 C1018
K8124	LOWER BARREL	DUCTILE IRON, ANSI/AWWA C151/A21.51
K8125	ELBOW O-RING	BUNA N, ASTM D2000
K8126A	SEAT RING UPPER O-RING	BUNA N, ASTM D2000
K8127	SEAT RING INSERT/RETAINING RING	BRONZE, ASTM B584 C83600/C84400
K8128	SEAT RING	BRONZE, ASTM B584 C83600/C84400
K8129	DRAIN TUBE	BRONZE, ASTM B135 C33000
K8130	SEAT RING LOWER O-RING	BUNA N, ASTM D2000
K8131	MAIN VALVE	EDPM w/ STEEL INSERT, ASTM D2000
K8132	BOTTOM PLATE	CAST IRON, ASTM A126, CLASS B
K8133	DRAIN VALVE PIN	STAINLESS STEEL, 410/416
K8134	ELBOW	DUCTILE IRON, ASTM A536 GRADE 70-50-05
K8135	ELBOW NUTS AND BOLTS	18-8 STAINLESS STEEL, F593C/F594
K8136	DRAIN VALVE	ALUM. BRONZE, ASTM B806 C95400/C95500
K8137	DRAIN VALVE FACING w/ INSERT	BUNA N, STAINLESS STEEL, ASTM D2000, ASTM A276 (304)
K8140	HOSE NOZZLE	BRONZE, ASTM B584 C83600
K8141	HOSE/PUMPER NOZZLE RETAINING SCREW	STAINLESS STEEL, ASTM A276 (304)
K8142	PUMPER NOZZLE	BRONZE, ASTM B584 C83600
K8143	HOSE/PUMPER NOZZLE CAP GASKET	NEOPRENE, ASTM D2000
K8144	HOSE/PUMPER NOZZLE CAP	CAST IRON, ASTM A126, CLASS B
K8145	HOSE/PUMPER NOZZLE O-RING	BUNA N, ASTM D2000
K8146	ALLEN HEAD SET SCREW	STAINLESS STEEL, ASTM A276 (410)
K8156	BREAKING RING STRAPS	E-COATED MILD STEEL

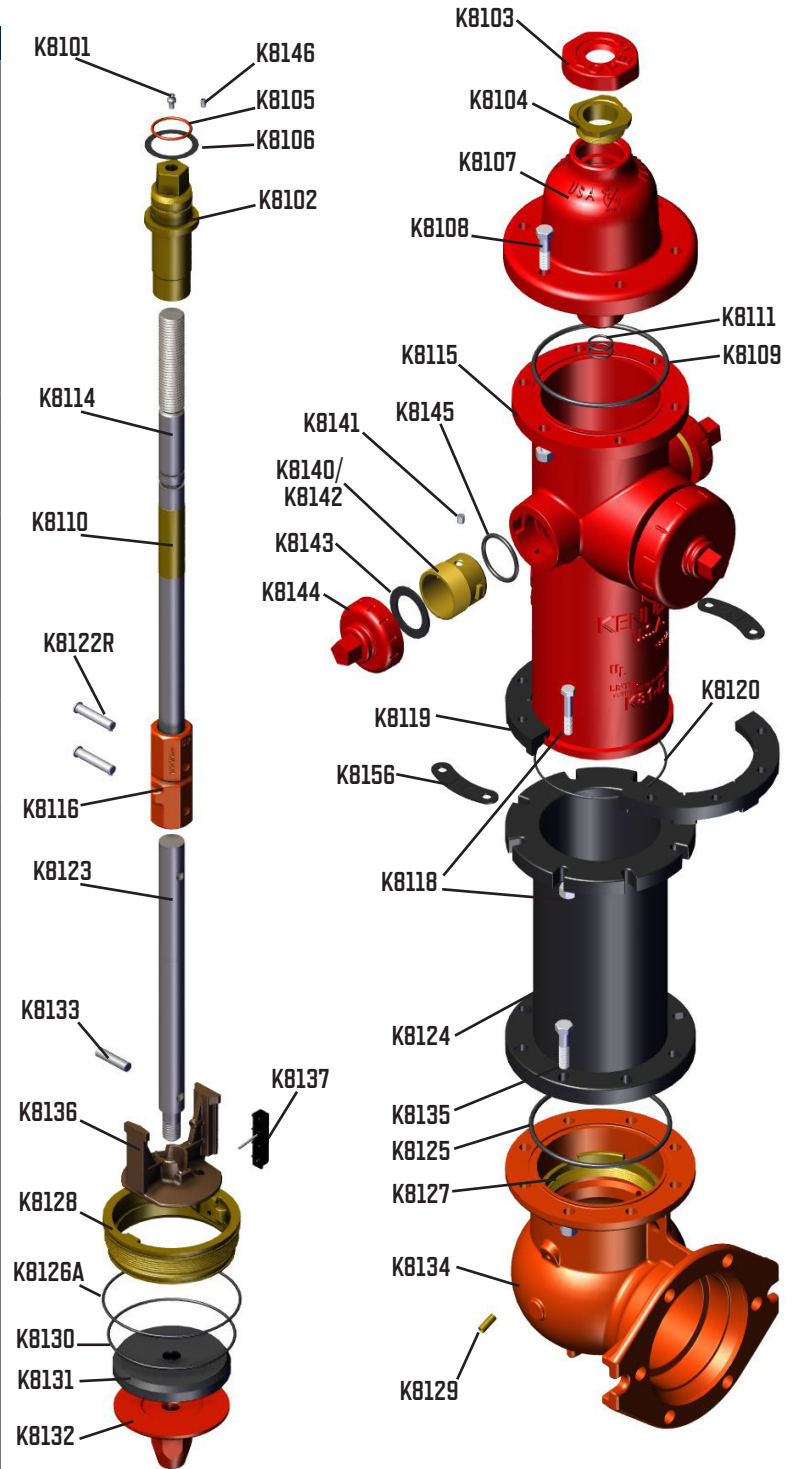

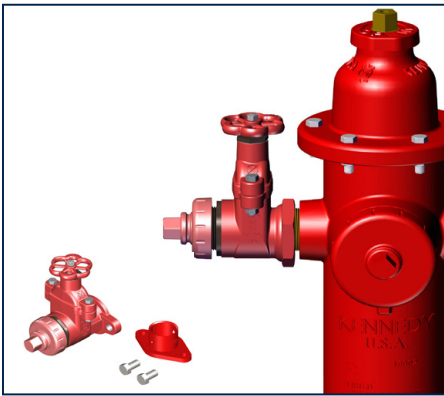

**Hose Gate Valve 2-1/2" Nozzle Outlet**  
Utilized when throttling hydrant flow.  
Available in bolt-on and screw-on options.

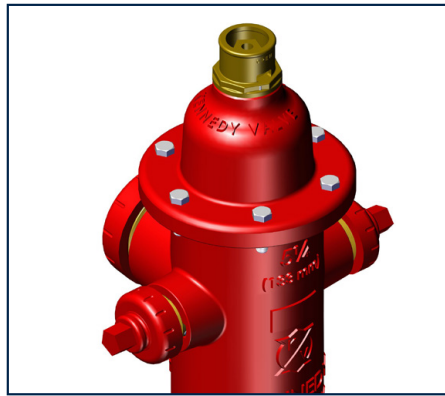

**Tamper Resistant Guardian Shield**  
Deep socket design deters unauthorized use.

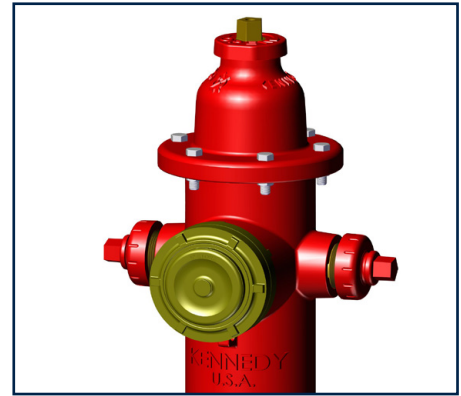

**Storz Nozzle 5-1/4" Pumper Outlet**  
Quick, universal 1/4 turn hose to hydrant connection for ease of operation.

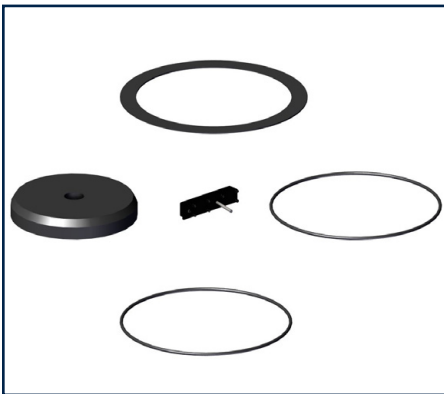

**K8151 Main Valve Repair Kit**  
Components to repair damaged main valve assembly.

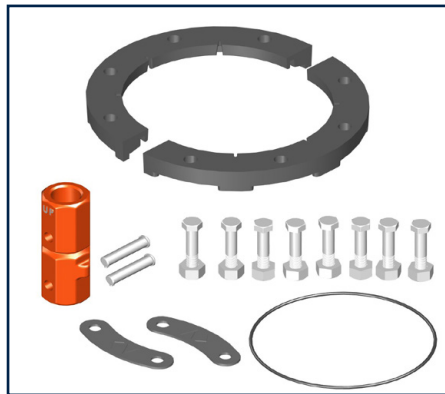

**K8149 Collision Repair Kit**  
Components to restore hydrant to service following a collision.



**K8150 Extension Kit**  
Components to increase bury depth of hydrant. Order in 6" increments.



**K8147 Seat Removal Wrench**  
Engages stem coupling for removing main valve seat. Used on 4-1/2" or 5-1/4" hydrant.

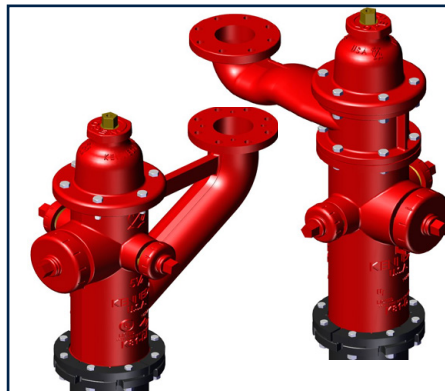

**K81-DI 350 Monitor Hydrant & K81-AM Monitor Hydrant**  
Provides the ability to mount a monitor nozzle in 3" or 4" flange pattern.

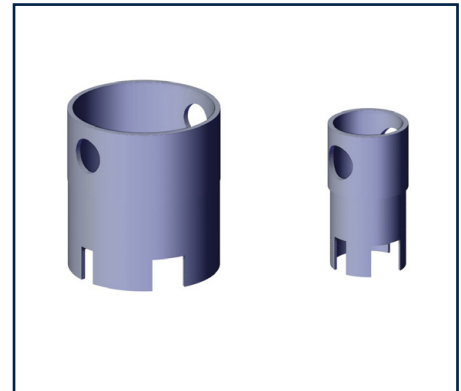

**K8148 Pumper and Hose Nozzle Wrench**  
Slots engage drive lugs in nozzle I.D. for removal. Order nozzle wrenches by I.D.



**KENNEDY VALVE**

## ORDERING INFORMATION

**PH:** 800-782-5831  
607-734-2211  
**FAX:** 800-952-4771

[SALES@KENNEDYVALVE.COM](mailto:SALES@KENNEDYVALVE.COM)  
[WWW.KENNEDYVALVE.COM](http://WWW.KENNEDYVALVE.COM)

## KENNEDY VALVE

1021 E. WATER ST.  
ELMIRA, NY  
14902-1516

## ORDERING DETAILS

When placing orders, requesting quotes or submittals, please supply information below:

- Size of the main valve opening
- Quantity and threading details of hose and steamer nozzles
- Type of inlet with size connection
  - Elbow
  - Straight Shoe
- Type of inlet connection
- Mechanical Joint
  - Flanged
  - Tyton
  - HDPE
- Depth of bury from bottom of pipe to ground line
- Op-Nut Size & Shape
- Open Direction
- Color Scheme



For Generations