

DURA PIPE™

EPOXY CATALOG

**ENHANCED EPOXY COATED
CAST IRON PIPE & FITTINGS
FOR AGGRESSIVE APPLICATIONS**



DURA PIPE™ TABLE OF CONTENTS

NO-HUB EPOXY	3 - 20
HUB & SPIGOT EPOXY	21 - 49
SPECIFICATIONS	51 - 53
SUBMITTALS	54 - 63
NO-HUB	54 - 58
HUB & SPIGOT	59 - 61
HUSKY CR 7000 COUPLING	62 - 64
INSTALLATION GUIDES	65 - 71
HUSKY CR 7000 COUPLING	65 - 67
HUB & SPIGOT	68 - 69
CUTTING INSTRUCTIONS	70
CAULKING INSTRUCTIONS	71

CREATION OF THIRD PARTY REVIT/CAD DRAWINGS WITHOUT AUTHORIZATION FROM MCWANE PLUMBING GROUP IS PROHIBITED.

WARNING! TESTING WITH COMPRESSED AIR OR GAS IN CAST IRON PIPE AND FITTINGS MAY RESULT IN EXPLOSIVE FAILURE AND COULD CAUSE SEVERE INJURY OR DEATH.

MCWANE PLUMBING GROUP RECOMMENDS HYDROSTATIC TESTING AS DESCRIBED IN THE CISPI HANDBOOK. NEVER TEST CAST IRON PIPE OR FITTINGS WITH COMPRESSED AIR OR GAS!



EPOXY NO-HUB PIPE

DuRa Pipe No-Hub USA  Manufacturing Date

NO-HUB PIPE, 10' LAYING LENGTH

Part No	Diameter	Per Bundle Piece	Bundle Weight
160001	2	64	2304
160003	3	48	2496
160005	4	30	2220
160007	5	24	2256
160009	6	21	2310
160011	8	15	2700
160013	10	8	2064
160015	12	6	1950
160017	15	3	1416

DIMENSIONS AND TOLERANCES NO-HUB PIPE BARRELS

Size	B Inside	J Outside	-T Thickness-	
	Diameter	Diameter	Norm.	Min.
1½"	1.50±.09	1.90±.06	.16	.13
2"	1.96±.09	2.35±.09	.16	.13
3"	2.96±.09	3.35±.09	.16	.13
4"	3.94±.09	4.38±.09--.05	.19	.15
5"	4.94±.09	5.30±.09--.05	.19	.15
6"	5.94±.09	6.30±.09--.05	.19	.15
8"	7.94±.13	8.38±.13--.09	.23	.17
10"	10.00 ±.13	10.56 ±.09	.28	.22
12"	11.94±.13	12.50±.13	.28	.22
15"	15.11±.13	15.83±.13	.36	.30



EPOXY NO-HUB FITTINGS

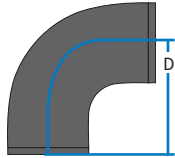

1/4 BEND

Part No.	Size	D
160026	2"	4½
160027	3"	5
160028	4"	5½
160029	5"	6½
160030	6"	7
160031	8"	8½

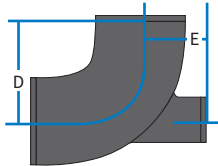

1/4 BEND w/ 2" LOW HEEL OPENING

Part No.	Size	D	E
160045	3 x 2"	5	2⅞
160046	4 x 2"	5½	3¼

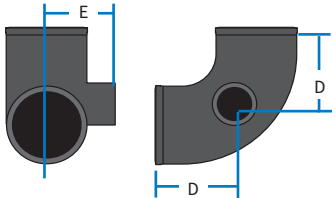

1/4 BEND w/ 2" SIDE OPENING

Part No.	Size	D	E
160060	3 x 2"	4	3¼
160061	4 x 2"	4⅝	3¾



EPOXY NO-HUB FITTINGS

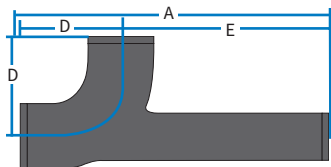

1/4 BEND w/ 2" EXTENDED LOW HEEL INLET

Part No.	Size	A	D	E
160055	3 x 2"	15½	5	10½

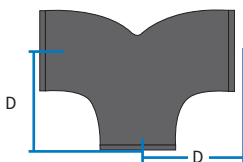

DOUBLE 1/4 BEND

Part No.	Size	D
160050	2"	4½
160051	3"	5
160052	4"	5½

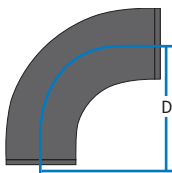

1/4 BEND SHORT SWEEP

Part No.	Size	D
160190	2"	6½
160191	3"	7
160192	4"	7½
160193	5"	8½
160194	6"	9
160195	8"	10½
160196	10"	12
160197	12"	13¼
160198	15"	14¾



EPOXY NO-HUB FITTINGS

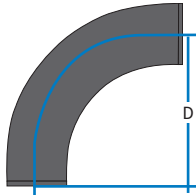

LONG SWEEP

Part No.	Size	D
160205	2"	9½
160206	3"	10
160207	4"	10½
160209	4 x 3"	10½
160210	5"	11½
160208	6"	12

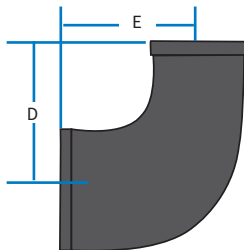

REDUCING ¼ BEND

Part No.	Size	D	E
160032	4 X 3"	5½	5

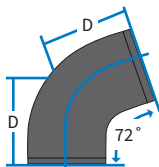

1/5 BEND

Part No.	Size	D
160070	2"	3 11/16
160071	3"	4 1/16
160072	4"	4 7/16



EPOXY NO-HUB FITTINGS

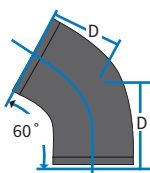

1/6 BEND

Part No.	Size	D
160075	2"	3 ¹ / ₄
160076	3"	3 ¹ / ₂
160077	4"	3 ¹³ / ₁₆

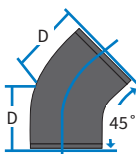

1/8 BEND

Part No.	Size	D
160081	2"	2 ³ / ₄
160082	3"	3
160083	4"	3 ¹ / ₈
160084	5"	3 ⁷ / ₈
160085	6"	4 ¹ / ₁₆
160086	8"	5
160087	10"	5 ¹⁵ / ₁₆
160088	12"	6 ⁹ / ₁₆
160089	15"	7 ³ / ₁₆



EPOXY NO-HUB FITTINGS

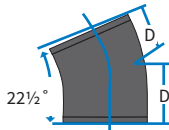

1/16 BEND

Part No.	Size	D
160095	2"	2 1/8
160096	3"	2 1/4
160097	4"	2 5/16
160098	5"	2 7/8
160099	6"	3
160100	8"	3 3/4

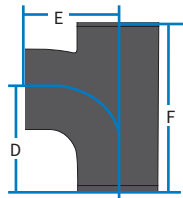

SAN TEE

Part No.	Size	D	E	F
160221	2"	4 1/2	4 1/2	6 7/8
160222	3 x 2"	4 1/2	5	6 7/8
160223	3"	5	5	8
160224	4 x 2"	4 1/2	5 1/2	6 7/8
160225	4 x 3"	5	5 1/2	8
160226	4"	5 1/2	5 1/2	9 1/8
160227	5 x 2"	5	6	8 1/2
160228	5 x 3"	5 1/2	6	9 5/16
160237	5 x 4"	6	6	10 13/32
160238	5"	6 1/2	6 1/2	11 7/16
160229	6 x 2"	5	6 1/2	8 3/16
160230	6 x 3"	5 1/2	6 1/2	9 3/16
160231	6 x 4"	6	6 1/2	10 1/16
160232	6"	7	7	12 1/2
160233	8 x 3"	6	7 1/2	10 3/8
160234	8 x 4"	6 1/2	7 1/2	11 1/2
160235	8 x 6"	7 1/2	8	13 1/2
160236	8"	8 1/2	8 1/2	15 1/2



EPOXY NO-HUB FITTINGS

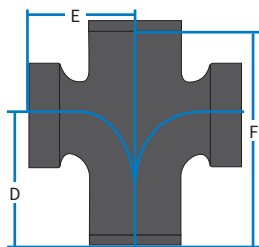

SAN TAP CROSS

Part No.	Size	D	E	F
160258	2 x 1½"	¾	2 ¹³ / ₁₆	5 ¹¹ / ₁₆
160259	2 x 2"	¾	3 ¹ / ₁₆	3 ³ / ₈

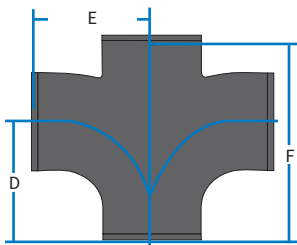

SAN CROSS

Part No.	Size	D	E	F
160102	2"	4½	4½	6 ⁷ / ₈
160103	3 x 2"	4½	5	6 ⁷ / ₈
160104	3"	5	5	8
160105	4 x 2"	4½	5½	6 ⁷ / ₈
160106	4 x 3"	5	5½	8
160107	4"	5½	5½	9 ¹ / ₈
160108	6 x 4"	6	6½	10 ¹ / ₁₆
160109	6"	7	7	12 ¹ / ₂
160110	8 x 4"	6½	7½	11 ¹ / ₂
160111	8"	8½	8½	15 ¹ / ₂



EPOXY NO-HUB FITTINGS

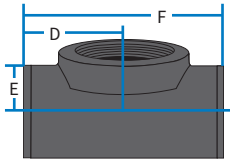

TEST TEE w/ PLUG

Part No.	Size	E	F	D
160285	2"	2	6 ³ / ₈	3 ³ / ₁₆
160286	3"	2 ¹ / ₁₆	7 ³ / ₄	3 ⁷ / ₈
160287	4"	3	8 ⁷ / ₈	4 ⁷ / ₁₆
160290	5"	4 ¹ / ₂	11 ¹ / ₂	5 ³ / ₄
160288	6"	5	12 ¹ / ₂	6 ¹ / ₄
160289	8"	6	15 ¹ / ₄	7 ⁵ / ₈

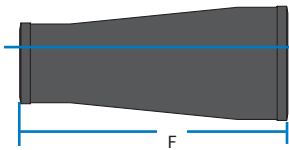

INCREASER – REDUCER

Part No.	Size	F
160155	3 x 4"	8



EPOXY NO-HUB FITTINGS

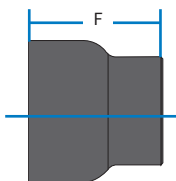

REDUCER (short)

Part No.	Size	F
160161	3 x 2"	3 ⁵ / ₈
160156	4 x 2"	3 ⁵ / ₈
160157	4 x 3"	3 ⁵ / ₈
160158	5 x 4"	4
160159	6 x 2"	4
160160	6 x 3"	4
160162	6 x 4"	4
160154	6 x 5"	4 ¹ / ₂
160163	8 x 2"	4 ¹ / ₂
160164	8 x 3"	4 ¹ / ₂
160165	8 x 4"	4 ¹ / ₂
160166	8 x 6"	5
160167	10 x 4"	5 ¹ / ₂
160168	10 x 6"	6
160169	10 x 8"	6
160170	12 x 4"	6 ¹ / ₂
160171	12 x 6"	6 ¹ / ₂
160172	12 x 8"	7
160173	12 x 10"	7 ¹ / ₂
160174	15 x 4"	7
160175	15 x 6"	7
160176	15 x 8"	7
160177	15 x 10"	7 ¹ / ₂
160178	15 x 12"	7 ³ / ₄



EPOXY NO-HUB FITTINGS

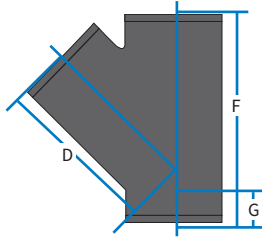

WYE

Part No.	Size	D	F	G
160325	2"	4 ⁵ / ₈	6 ⁵ / ₈	2
160326	3 x 2"	5 ⁵ / ₁₆	6 ⁵ / ₈	1 ¹ / ₂
160327	3"	5 ³ / ₄	8	2 ¹ / ₄
160328	4 x 2"	6	6 ⁵ / ₈	1
160329	4 x 3"	6 ¹ / ₂	8	1 ¹¹ / ₁₆
160330	4"	7 ¹ / ₁₆	9 ¹ / ₂	2 ⁷ / ₁₆
160331	5 x 2"	7 ¹ / ₂	8 ¹ / ₁₆	1 ⁵ / ₁₆
160332	5 x 3"	8	9 ¹¹ / ₁₆	1 ¹¹ / ₁₆
160333	5 x 4"	8 ¹ / ₂	11 ³ / ₁₆	2 ⁷ / ₁₆
160348	5"	9 ¹ / ₂	12 ⁵ / ₈	3 ³ / ₈
160334	6 x 2"	8 ¹ / ₄	8 ⁵ / ₁₆	1/2
160335	6 x 3"	8 ³ / ₄	9 ³ / ₄	1 ¹ / ₄
160336	6 x 4"	9 ¹ / ₄	11 ³ / ₁₆	1 ¹⁵ / ₁₆
160337	6"	10 ³ / ₄	14 ¹ / ₁₆	3 ⁵ / ₁₆
160338	8 x 3"	9 ¹³ / ₁₆	9 ¹⁵ / ₁₆	1/8
160339	8 x 4"	10 ³ / ₈	11 ⁷ / ₁₆	1 ⁵ / ₁₆
160340	8 x 6"	11 ¹³ / ₁₆	14 ³ / ₁₆	2 ¹⁵ / ₁₆
160341	8"	13 ³ / ₈	17 ¹ / ₈	3 ³ / ₄
160342	10 x 4"	11 ¹¹ / ₁₆	12 ⁵ / ₈	3/4
160343	10 x 6"	13 ¹ / ₈	15 ⁷ / ₁₆	2 ³ / ₁₆
160344	10 x 8"	14 ¹¹ / ₁₆	18 ³ / ₈	3 ⁵ / ₈
160345	10"	16 ¹ / ₂	21 ¹ / ₂	5 ¹ / ₁₆
160346	12"	19 ³ / ₄	25 ¹ / ₂	5 ³ / ₄
160347	15"	23 ¹ / ₄	30	6 ³ / ₄



EPOXY NO-HUB FITTINGS

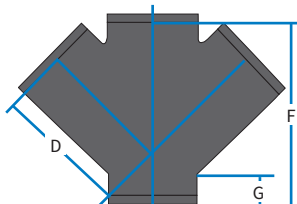

DOUBLE WYE

Part No.	Size	D	F	G
160355	2"	4 ⁵ / ₈	6 ⁵ / ₈	2
160356	3 x 2"	5 ¹ / ₁₆	6 ⁵ / ₈	1 ¹ / ₂
160357	3"	5 ³ / ₄	8	2 ¹ / ₄
160358	4 x 2"	6	6 ⁵ / ₈	1 ¹ / ₂
160359	4 x 3"	6 ¹ / ₂	8	1 ¹¹ / ₁₆
160360	4"	7 ¹ / ₁₆	9 ¹ / ₂	2 ⁷ / ₁₆
160361	6 x 4"	9 ¹ / ₄	11 ³ / ₁₆	1 ¹⁵ / ₁₆
160362	6"	10 ³ / ₄	14 ¹ / ₁₆	3 ⁵ / ₁₆
160363	8 x 4"	10 ³ / ₈	11 ⁷ / ₁₆	2 ⁵ / ₁₆
160364	8 x 6"	11 ¹³ / ₁₆	14 ³ / ₁₆	2 ⁵ / ₁₆
160365	8"	13 ³ / ₈	17 ¹ / ₈	3 ³ / ₄

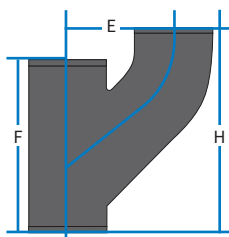

UPRIGHT WYE

Part No.	Size	E	H	F
160370	2"	5 ¹ / ₂	10 ¹ / ₄	7
160371	3 x 2"	5 ¹ / ₂	9 ¹¹ / ₁₆	7
160372	3"	5 ¹ / ₂	10 ⁵ / ₈	8 ³ / ₈
160373	4 x 2"	5 ¹ / ₂	9 ¹ / ₄	7
160374	4 x 3"	5 ¹ / ₂	10 ¹ / ₈	8 ³ / ₈
160375	4"	6	11 ⁹ / ₁₆	9 ³ / ₄
160376	5 x 2"	6 ³ / ₄	10	8
160377	5"	7 ¹ / ₈	14 ³ / ₁₆	12 ¹¹ / ₁₆



EPOXY NO-HUB FITTINGS

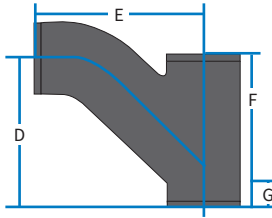

COMBINATION

Part No.	Size	D	E	F	G
160260	2"	5 ³ / ₈	6 ¹ / ₈	6 ⁵ / ₈	2
160261	3 x 2"	5 ¹ / ₂	6 ³ / ₄	6 ⁵ / ₈	1 ¹ / ₂
160262	3"	7 ⁵ / ₁₆	8	8	2 ¹ / ₄
160263	4 x 2"	5 ¹ / ₂	7 ¹ / ₄	6 ⁵ / ₈	1 ⁵ / ₈
160264	4 x 3"	7 ¹ / ₄	8 ¹ / ₂	8	1 ¹¹ / ₁₆
160265	4"	9 ¹ / ₄	10	9 ¹ / ₂	2 ⁷ / ₁₆
160273	5 x 2"	5 ¹⁵ / ₁₆	7 ³ / ₄	8 ¹ / ₁₆	1 ⁵ / ₁₆
160274	5 x 3"	7 ³ / ₄	9	9 ¹¹ / ₁₆	1 ¹¹ / ₁₆
160275	5 x 4"	9 ³ / ₄	10 ¹ / ₂	11 ³ / ₁₆	2 ⁷ / ₁₆
160276	5"	11 ³ / ₄	12 ¹ / ₂	12 ⁵ / ₈	3 ¹ / ₈
160266	6 x 2"	6	8 ¹ / ₄	8 ⁵ / ₁₆	1/2
160267	6 x 3"	7 ³ / ₁₆	9 ¹ / ₂	9 ³ / ₄	1 ¹ / ₄
160268	6 x 4"	9 ³ / ₄	11	11 ³ / ₁₆	1 ¹⁵ / ₁₆
160269	6"	13 ⁵ / ₈	14 ³ / ₈	14 ¹ / ₁₆	3 ⁵ / ₁₆
160270	8 x 4"	9 ⁷ / ₁₆	11 ⁵ / ₁₆	11 ³ / ₁₆	7/8
160271	8 x 6"	12	13 ³ / ₈	13 ¹⁵ / ₁₆	2 ¹ / ₄
160272	8"	14 ³ / ₄	15 ⁹ / ₁₆	16 ¹⁵ / ₁₆	3 ³ / ₄



EPOXY NO-HUB FITTINGS

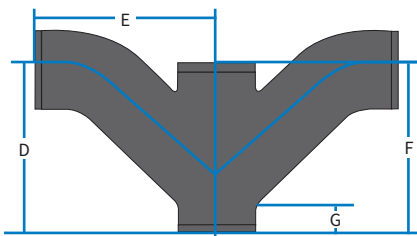

DOUBLE COMBINATION

Part No.	Size	D	E	F	G
160062	2"	5 ³ / ₈	6 ¹ / ₈	6 ⁵ / ₈	2
160063	3 x 2"	5 ¹ / ₂	6 ³ / ₄	6 ⁵ / ₈	1 ¹ / ₂
160064	3"	7 ⁵ / ₁₆	8	8	2 ¹ / ₄
160065	4 x 2"	5 ¹ / ₂	7 ¹ / ₄	6 ⁵ / ₈	1 ⁵ / ₈
160066	4 x 3"	7 ¹ / ₄	8 ¹ / ₂	8	1 ¹ / ₁₆
160067	4"	9 ¹ / ₄	10	9 ¹ / ₂	2 ⁷ / ₁₆

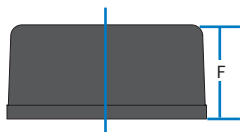

BLIND PLUG

Part No.	Size	F
160140	2"	1 ³ / ₄
160141	3"	1 ³ / ₄
160142	4"	1 ³ / ₄
160143	5"	1 ³ / ₄
160144	6"	1 ³ / ₄
160145	8"	2 ¹ / ₄
160146	10"	3
160147	12"	3 ¹ / ₂
160148	15"	3 ¹ / ₂



EPOXY NO-HUB FITTINGS

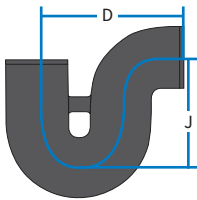

“P” TRAP

Part No.	Size	D	J
160295	2”	7½	4
160296	3”	9	5½
160297	4”	10½	6½
160298	6”	14	8½

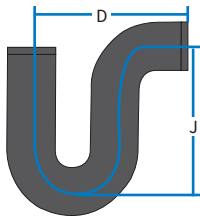

DEEP SEAL “P” TRAP

Part No.	Size	D	J
160315	2”	7½	7
160316	3”	9	7
160317	4”	10½	8

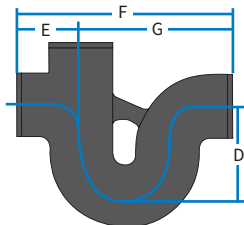

RUNNING TRAP (with 4” single vent)

Part No.	Size	D	E	F	G
160320	4 x 4”	6½	4½	15	10½



EPOXY NO-HUB FITTINGS

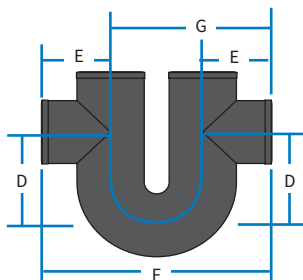

RUNNING TRAP WITH DOUBLE VENT

Part No.	Size	D	E	F	G
160321	4"	6½	4½	15	10½

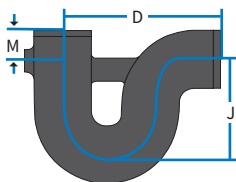

"P" TRAP (with ½" tap primer)

Part No.	Size	D	J	M	Tap
160305	2"	7½	4	2	½
160306	3"	9	5½	2	½
160307	4"	10½	6½	2	½



EPOXY NO-HUB FITTINGS

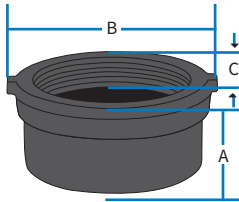

IRONBODY CLEANOUT (Ferrule) (with Type A plug)

Part No.	Size	Tap	A	B	C
160120	2"	1½"	2 ³ / ₁₆	2 ³ / ₈	¾
160121	3"	2½"	2 ³ / ₁₆	3 ³ / ₈	¾
160122	4"	3½"	2 ³ / ₁₆	4 ⁷ / ₁₆	¾
160123	6"	5"	4½	6 ⁵ / ₁₆	1
160124	8"	6"	4 ⁵ / ₈	8 ³ / ₈	1

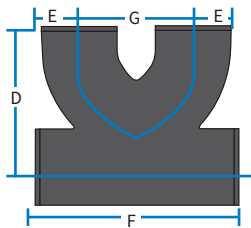

TWO WAY CLEANOUT

Part No.	Size	D	E	F	G
160130	4 x 4 x 4"	8¼	2¾	12	6½



EPOXY NO-HUB FITTINGS

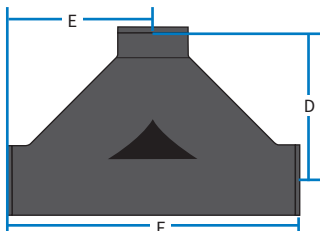

TWO-WAY BAFFLE CLEANOUT

Part No.	Size	E	D	F
160131	3 x 3 x 4"	7½	9	15
160132	4 x 4 x 4"	9¾	9½	18¾

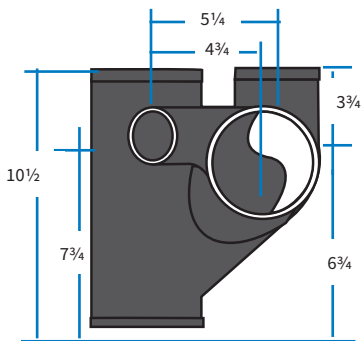

9-399 VENTED CLOSET CROSS (NO BAFFLE)

Part No.	Size
160090*	4 x 3 x 2 x 4"

*Note: Not listed by IAPMO



EPOXY NO-HUB FITTINGS

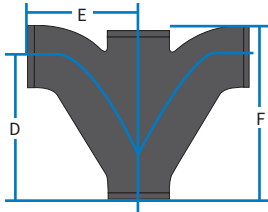
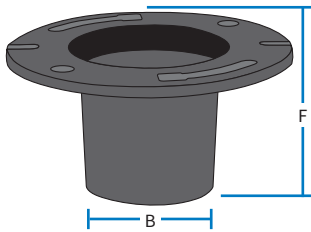

FIGURE 5

Part No.	Size	D	E	F
160115	2"	6½	5	8
160117	3 x 2 x 3 x 3"	8⅞	6⅞ ₁₆	9¼
160116	3"	8⅞	6⅞ ₁₆	10⅛
160119	4 x 2 x 4 x 4"	10¼	7¾	11½
160118	4"	10¼	7¾	12



9-480 CLOSET FLANGE

Part No.	Size	B	F
160134	4 x 3 x 3½"	3⅝ ₁₆	3½
160135	4 x 3" x 8	3⅝ ₁₆	8
160136	4 x 4 x 4	4⅝ ₁₆	4
160137	4 x 4 x 8	4⅝ ₁₆	8



EPOXY SERVICE WEIGHT PIPE



SV SINGLE HUB PIPE

10 Ft.	Part No.	Size	Pcs/ Pkg	Wt.
	170001	2"	36	1368
	170003	3"	36	1872
	170005	4"	27	2052
	170007	5"	24	2328
	170009	6"	18	2070
	170011	8"	15	2850
	170013	10"	8	2160
	170015	12"	6	2130
	170017	15"	3	1545



SV DOUBLE HUB PIPE

30"	Part No.	Size
	170020	2"
	170021	3"
	170022	4"



EPOXY SERVICE WEIGHT FITTINGS

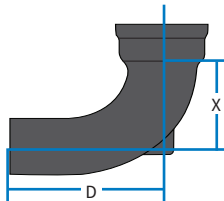

1/4 BEND

Part No.	Size	X	D
170050	2"	3 ¹ / ₄	6
170051	3"	4	7
170052	4"	4 ¹ / ₂	8
170058	5"	5	8 ¹ / ₂
170053	6"	5 ¹ / ₂	9
170054	8"	6 ⁵ / ₈	11 ¹ / ₂
170055	10"	7 ⁵ / ₈	12 ¹ / ₂
170056	12"	8 ³ / ₄	15
170057*	15"	10 ¹ / ₄	16 ¹ / ₂

*xh only

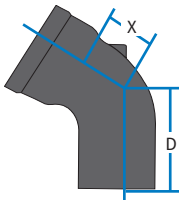

1/6 BEND

Part No.	Size	X	D
170065	2"	2	4 ³ / ₄
170066	3"	2 ¹ / ₂	5 ¹ / ₂
170067	4"	2 ¹³ / ₂₆	6 ⁵ / ₁₆
170068	6"	3 ³ / ₈	6 ⁷ / ₈
170069	8"	4 ¹ / ₈	9



EPOXY SERVICE WEIGHT FITTINGS

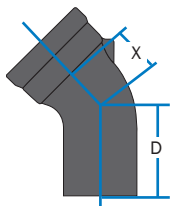

1/8 BEND

Part No.	Size	X	D
170075	2"	1½	4¼
170076	3"	1 ⁵ / ₁₆	4 ¹⁵ / ₁₆
170077	4"	2 ³ / ₁₆	5 ¹¹ / ₁₆
170083	5"	2 ³ / ₈	5 ⁷ / ₈
170078	6"	2 ⁹ / ₁₆	6 ¹ / ₁₆
170079	8"	3 ³ / ₈	8
170080	10"	3½	8 ³ / ₈
170081	12"	4 ¹ / ₁₆	10 ⁵ / ₁₆
170082*	15"	4 ¹ / ₁₆	10 ¹⁵ / ₁₆

*xh only

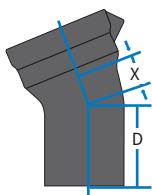

1/16 BEND

Part No.	Size	X	D
170090	2"	7/8	3 ⁵ / ₈
170091	3"	1 ³ / ₁₆	4 ³ / ₁₆
170092	4"	1 ⁵ / ₁₆	4 ¹³ / ₁₆
170093	6"	1½	5
170094	8"	1 ¹³ / ₁₆	6 ¹¹ / ₁₆
170095	10"	2	6 ⁷ / ₈
170096	12"	2 ³ / ₈	8 ⁵ / ₈
170097*	15"	2 ⁵ / ₈	8 ⁷ / ₈

*xh only



EPOXY SERVICE WEIGHT FITTINGS

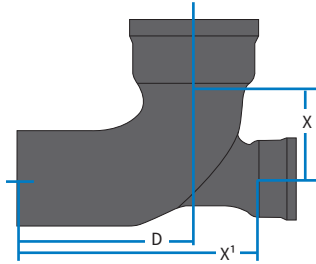

1/4 BEND w/ LOW HEEL INLET

Part No.	Size	X	X'	D
170105	3 x 2"	4	9	7
170106	4 x 2"	4½	10½	8

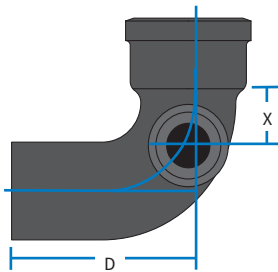

1/4 BEND w/ 2" HUB SIDE OPENING

Part No.	Size	D	X
170107	4" w/2" LH	8	4½
170108	4" w/2" RH	8	4½



EPOXY SERVICE WEIGHT FITTINGS

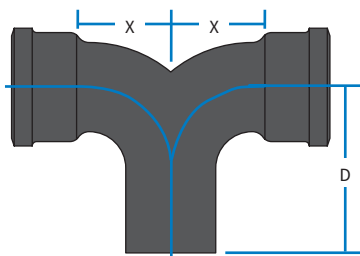

DOUBLE 1/4 BEND

Part No.	Size	D	X
170115	4"	8	4½

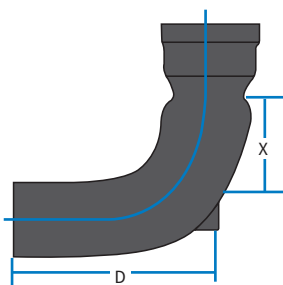

REDUCING 1/4 BEND

Part No.	Size	X	D
170140	3 x 2"	3¾	7
170141	4 x 2"	3½	7
170142	4 x 3"	4¼	8½



EPOXY SERVICE WEIGHT FITTINGS

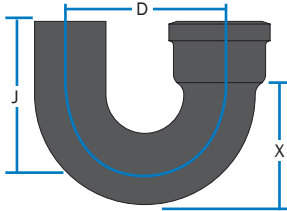

SINGLE HUB RETURN BEND

Part No.	Size	X	D	J
170145	3"	6	7	7
170146	4"	6 ¹ / ₃₀	8	7 ¹ / ₂

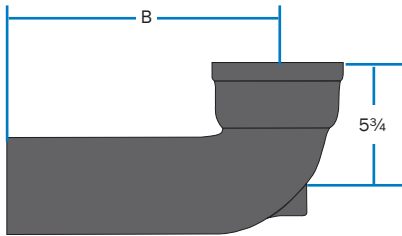

CLOSET BENDS — 2-256 SV ONLY

Part No.	Size	B
170173	4"	12
170174	4"	14
170175	4"	16
170176	4"	18



EPOXY SERVICE WEIGHT FITTINGS

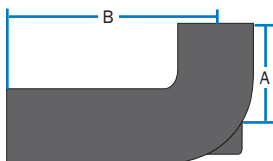

CLOSET BENDS — 2-253

Part No.	Size	A	B
170150	3	16	16
170151	4	4	12
170152	4	4	16
170153	4	4	18
170154	4	6	12
170155	4	6	16
170156	4	6	18
170157	4	8	16
170158	4	10	12
170159	4	10	16
170160	4	12	12
170161	4	12	16
170162	4	12	18
170163	4	14	16
170164	4	14	18
170165	4	16	16
170166	4	16	18
170167	4	18	18

CLOSET BENDS — 2-254 (Reducing)

Part No.	Size	A	B
170168	4X3	6	12
170169	4X3	6	16
170170	4X3	12	12
170171	4X3	16	16
170172	4X3	18	18



EPOXY
SERVICE WEIGHT FITTINGS

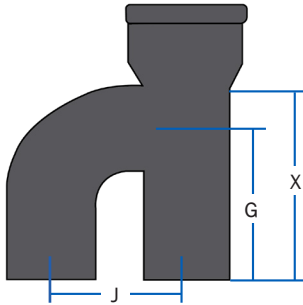

VENT BRANCH

Part No.	Size	X	J	G
170180	4"	11	6½	8

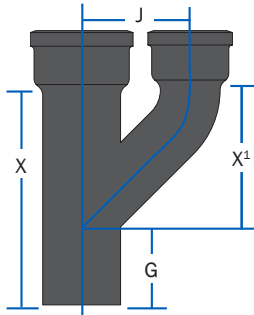

"H" BRANCH

Part No.	Size	X	X¹	J	G
170181	4"	13 ¹⁵ / ₁₆	8 ¹¹ / ₁₆	6½	5¼
170182	4 x 3"	12 ³ / ₁₆	7 ⁵ / ₁₆	6	4½



EPOXY SERVICE WEIGHT FITTINGS

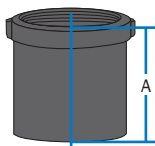

2-11 STANDARD FERRULE W/ TYPE A PLUG

Part No.	Pipe Size	Tap Size	A
170195	2"	1½	3½
170196	3"	2½	3¾
170197	4"	3	3¼
170198	6"	5	4¼
170199	8"	6	4½
170200	10"	6	4½
170201	12"	6	5¼

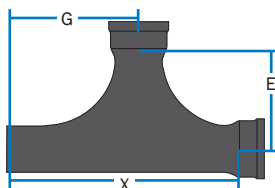

TWO-WAY CLEANOUT (Memphis Code)

Part No.	Size	X	E	G
170210	4"	22⅛	9⅜	12¾

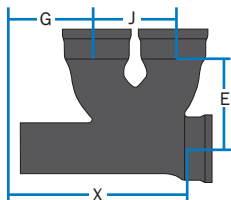

TWO-WAY DOUBLE CLEANOUT

Part No.	Size	X	E	G	J
170215	4"	13⅝	7½	6½	6⅞
170216	6 x 6 x 4 x 4"	13⅝	8½	6½	6⅞



EPOXY SERVICE WEIGHT FITTINGS

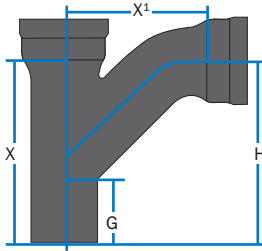

COMBINATION

Part No.	Size	X	G	X ¹	H
170220	2"	8	4	4 ⁷ / ₈	7 ³ / ₈
170221	3 x 2"	9	4 ³ / ₁₆	5 ³ / ₄	8 ³ / ₁₆
170222	3"	10 ¹ / ₂	5	7	10 ¹ / ₁₆
170223	4 x 2"	9	3 ¹ / ₁₆	6 ¹ / ₄	8 ³ / ₁₆
170224	4 x 3"	10 ¹ / ₂	4 ¹ / ₂	7 ¹ / ₂	10 ¹ / ₁₆
170225	4"	12	5 ¹ / ₄	9	12 ¹ / ₁₆
170226	6 x 2"	9	2 ¹ / ₁₆	7 ¹ / ₄	8 ³ / ₁₆
170227	6 x 3"	10	3 ³ / ₈	8 ¹ / ₂	9 ¹ / ₁₆
170228	6 x 4"	12	4 ¹ / ₄	10	12 ¹ / ₁₆
170229	6"	15	5 ³ / ₄	12 ⁷ / ₈	16 ¹ / ₁₆
170230	8 x 2"	10 ¹ / ₂	3 ³ / ₈	8 ³ / ₄	9 ⁵ / ₈
170231	8 x 4"	13 ¹ / ₂	4 ³ / ₄	11	13 ⁹ / ₁₆
170232	8 x 6"	16 ¹ / ₂	6 ⁵ / ₁₆	13 ⁷ / ₈	17 ⁵ / ₈
170233	8"	19 ¹ / ₂	7 ¹ / ₁₆	17	21 ⁹ / ₁₆



EPOXY SERVICE WEIGHT FITTINGS

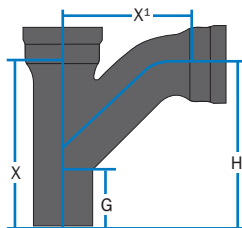

**COMBINATION
(SHORT TURN)**

Part No.	Size	X	G	X ¹	H
170240	4"	11 ³ / ₈	5 ⁷ / ₁₆	6 ¹ / ₂	4 ³ / ₈

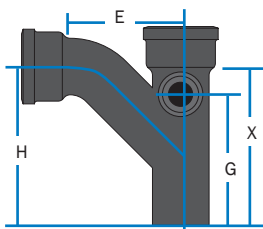

**COMBINATION
w/ HUB SIDE OPENING**

Part No.	Size	G	H	X	E
170245	4" w/2" LH	10	12 ¹ / ₁₆	12	9
170246	4" w/2" RH	10	12 ¹ / ₁₆	12	9



EPOXY SERVICE WEIGHT FITTINGS

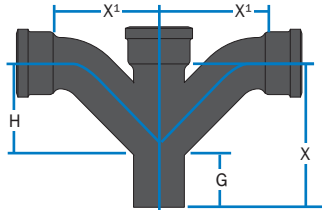

**DOUBLE COMBINATION
(SHORT TURN)**

Part No.	Size	X	H	X'	G
170252	4"	11 ³ / ₈	4 ³ / ₈	6 ¹ / ₂	5 ⁷ / ₈

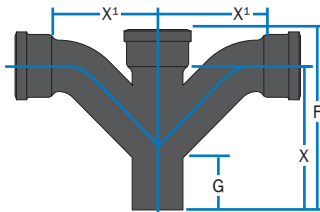

DOUBLE COMBINATION

Part No.	Size	X	X'	F	G
170255	2"	8	4 ⁷ / ₈	7 ³ / ₈	4
170256	3 x 2"	9	5 ³ / ₄	8 ³ / ₁₆	4 ³ / ₁₆
170257	3"	10 ¹ / ₂	7	10 ¹ / ₁₆	5
170258	4 x 2"	9	6 ¹ / ₄	8 ³ / ₁₆	3 ¹ / ₁₆
170259	4 x 3"	10 ¹ / ₂	7 ¹ / ₂	10 ¹ / ₁₆	4 ¹ / ₂
170260	4"	12	9	12 ¹ / ₁₆	5 ¹ / ₄
170261	6 x 4"	12	10	12 ¹ / ₁₆	4 ¹ / ₄
170262	6"	15	12 ⁷ / ₈	16 ¹ / ₁₆	5 ³ / ₄



EPOXY SERVICE WEIGHT FITTINGS

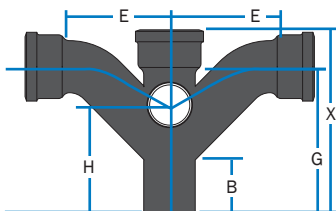

**DOUBLE COMBINATION
w/ 2" HUB SIDE OPENING**

Part No.	Size	X	B	E	G	H
170265	4"	12	5¼	9	12½/₁₆	10

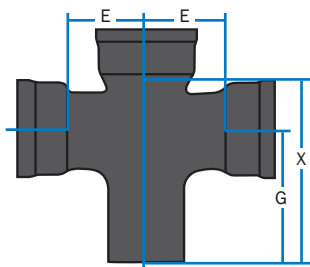

**SAN CROSS
(No Baffle)**

Part No.	Size	X	E	G
170270	2"	8	3¼	6¼
170271	3 x 2"	9	4	7
170272	3"	10	4	7½
170273	4 x 2"	9	4½	7
170274	4 x 3"	10	4½	7½
170275	4"	11	4½	8
170277	6"	13	5½	9
170276	6 x 4"	11	5½	8



**EPOXY
SERVICE WEIGHT FITTINGS**

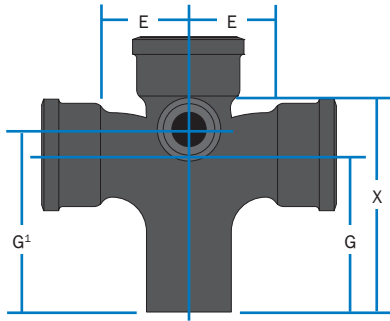

**SAN CROSS w/
2" SIDE OPENING**

Part No.	Size	G	G ¹	X	E
170278	4"	8	9	11	4½

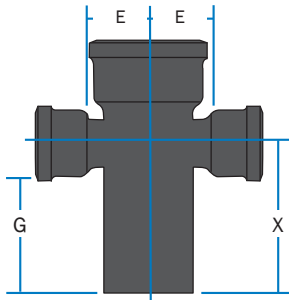

STRAIGHT CROSS

Part No.	Size	G	X	E
170285	4 x 2"	7	9	3
170286	4"	8	11	3



EPOXY SERVICE WEIGHT FITTINGS

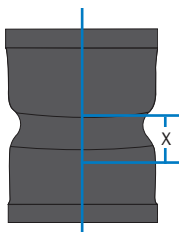

DOUBLE HUB FITTING

Part No.	Size	X
170295	2"	1
170296	3"	1
170297	4"	1
170298	6"	1
170299	8"	1½
170300	10"	1½
170301	12"	1½
170302*	15"	1½

*XH only

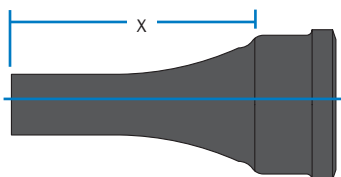

INCREASER

Part No.	Size	X
170320	2 x 4"	9
170321	3 x 4"	9
170322	4 x 6"	9
170323	4 x 8"	12
170324	6 x 8"	12
170325	8 x 10"	12



EPOXY SERVICE WEIGHT FITTINGS

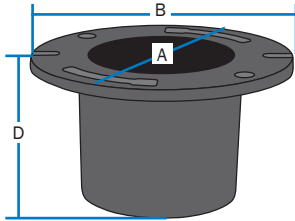

2-252 CLOSET FLANGE (Caulk Joint Application)

Part No.	Size x Height	A	B	D
170310	4 x 1"	6 $\frac{1}{4}$	7 $\frac{1}{4}$	1
170311	4 x 2"	6 $\frac{1}{4}$	7 $\frac{1}{4}$	2
170312	4 x 2 $\frac{1}{2}$ "	6 $\frac{1}{4}$	7 $\frac{1}{4}$	2 $\frac{1}{2}$
170313	4 x 3"	6 $\frac{1}{4}$	7 $\frac{1}{4}$	3
170314	4 x 4"	6 $\frac{1}{4}$	7 $\frac{1}{4}$	4
170315	4 x 6"	6 $\frac{1}{4}$	7 $\frac{1}{4}$	6

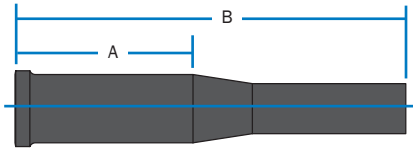

INSERTABLE JOINT

Part No.	Size	A	B
170330	2"	6	14
170331	3"	8	16
170332	4"	7	14 $\frac{1}{2}$
170333	6"	8 $\frac{1}{2}$	16 $\frac{3}{4}$
170334	8"	10	18



EPOXY SERVICE WEIGHT FITTINGS

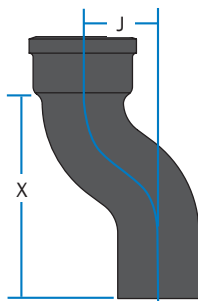

45° OFFSET

Part No.	Size	X	J
170350	4 x 4"	11	4
170351	4 x 6"	13	6
170352	4 x 8"	15	8

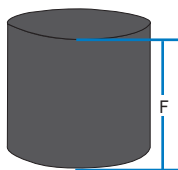

PIPE PLUG

Part No.	Size	F
170360	2"	3½
170361	3"	3¾
170362	4"	4
170363	6"	4
170364	8"	4½
170365	10"	4½
170366	12"	5¼
170367*	15"	5¼

*XH only



EPOXY SERVICE WEIGHT FITTINGS

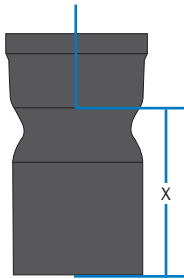

REDUCER

Part No.	Size	X
170375	3 x 2"	4 ³ / ₄
170376	4 x 2"	5
170377	4 x 3"	5
170378	5 x 4"	5
170379	6 x 2"	5
170380	6 x 3"	5
170381	6 x 4"	5
170382	8 x 3"	6
170383	8 x 4"	6
170384	8 x 6"	6
170385	10 x 4"	6
170386	10 x 6"	6
170387	10 x 8"	6
170388	12 x 4"	6 ¹ / ₂
170389	12 x 6"	6 ¹ / ₂
170390	12 x 8"	6 ¹ / ₂
170391	12 x 10"	6 ¹ / ₂
170392	15 x 6"	6 ¹ / ₂
170393	15 x 8"	6 ¹ / ₂
170394	15 x 10"	6 ¹ / ₂
170395	15 x 12"	6 ¹ / ₂



EPOXY SERVICE WEIGHT FITTINGS

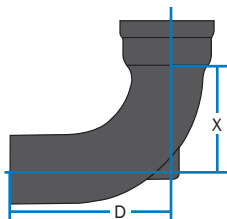

SHORT SWEEP BEND

Part No.	Size	X	D
170410	2"	5¼	8
170411	3"	6	9
170412	4"	6½	10
170413	6"	7½	11
170414	8"	8⅝	13½
170415	10"	9⅝	14½
170416	12"	10¾	17

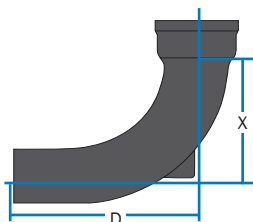

LONG SWEEP BEND

Part No.	Size	X	D
170420	2"	8¼	11
170421	3"	9	12
170422	4"	9½	13
170428	5"	10	13½
170423	6"	10½	14
170424	8"	11⅝	16½
170425	10"	12⅝	17½
170426	12"	13¾	20
170427*	15"	15¼	21½

*XH Only



EPOXY SERVICE WEIGHT FITTINGS

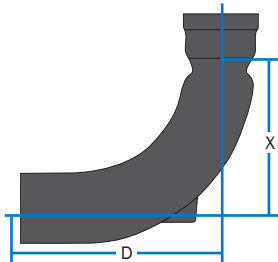

LONG SWEEP BEND, REDUCING

Part No.	Size	X	D
170435	3 x 2"	9	12
170436	4 x 3"	9½	13

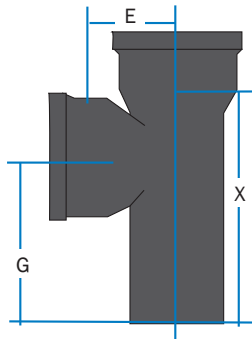

STRAIGHT TEE

Part No.	Size	X	E	G
170445	2"	8	1¼	6¼
170446	3 x 2"	9	2½	7
170447	3"	10	2½	7½
170448	4 x 2"	9	3	7
170449	4 x 3"	10	3	7½
170450	4"	11	3	8
170451	6 x 4"	11	4	8
170452	6"	13	4	9
170453	8 x 4"	12¾	5¼	9⅝



EPOXY SERVICE WEIGHT FITTINGS

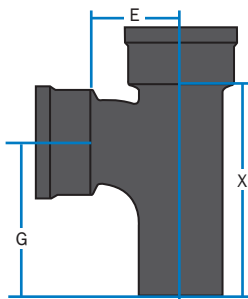

SAN TEE

Part No.	Size	X	E	G
170460	2"	8	2 ³ / ₄	6 ¹ / ₄
170461	3 x 2"	9	4	7
170462	3"	10	4	7 ¹ / ₂
170463	4 x 2"	9	4 ¹ / ₂	7
170464	4 x 3"	10	4 ¹ / ₂	7 ¹ / ₂
170465	4"	11	4 ¹ / ₂	8
170466	6 x 2"	9	5 ¹ / ₂	7
170467	6 x 3"	10	5 ¹ / ₂	7 ¹ / ₂
170468	6 x 4"	11	5 ¹ / ₂	8
170469	6"	13	5 ¹ / ₂	9
170470	8 x 4"	13	6 ¹ / ₂	9 ³ / ₄
170471	8 x 6"	15	6 ¹ / ₂	10 ³ / ₄
170472	8"	17	6 ⁵ / ₈	11 ³ / ₄
170473	10 x 4"	13	7 ¹ / ₂	9 ³ / ₄
170474	10 x 6"	15	7 ¹ / ₂	10 ³ / ₄
170475	10 x 8"	17	7 ⁵ / ₈	11 ³ / ₄
170476	10"	19	7 ⁵ / ₈	12 ³ / ₄
170477	12 x 6"	16 ¹ / ₂	8 ¹ / ₂	12
170478	12 x 8"	18 ¹ / ₂	8 ⁵ / ₈	13
170479	12 x 10"	20 ¹ / ₂	8 ⁵ / ₈	14
170480	12"	22 ¹ / ₂	8 ³ / ₄	15
170481	15 x 6"	16 ¹ / ₂	10	12
170482	15 x 8"	18 ¹ / ₂	10 ¹ / ₈	13
170483	15 x 12"	22 ¹ / ₂	10 ¹ / ₄	15
170484*	15"	25 ¹ / ₂	10 ¹ / ₄	16 ¹ / ₂

*XH only



EPOXY SERVICE WEIGHT FITTINGS

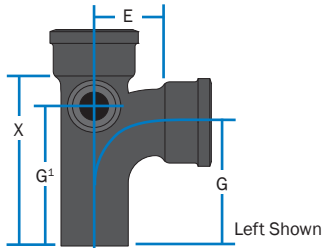

SAN TEE WITH SIDE INLET

Part No.	Size	G	G ¹	X	E
170490	4" w/2" LH	8	9	11	4½
170491	4" w/2" RH	8	9	11	4½

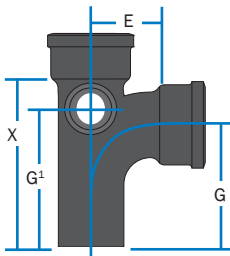

SAN TEE WITH RIGHT AND LEFT HAND SIDE TAPS

Part No.	Size	G	G ¹	X	E
170492	4" w/2"	8	9	11	4½

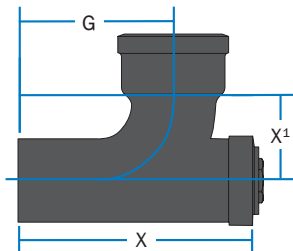

SAN TEE WITH CLEANOUT ON MAIN

Part No.	Size	IPS Tap	G	X	X ¹
170495	4"	3½	8	12⅞	4½



EPOXY SERVICE WEIGHT FITTINGS

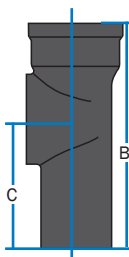

2-70 TEST TEE WITH TYPE A PLUG

Part No.	Pipe Size	Tap Size	B	C
170510	2"	2	8	6
170511	3"	3	10 $\frac{1}{8}$	7 $\frac{3}{8}$
170513	4"	4	11 $\frac{1}{8}$	8
170514	6"	6	13	8 $\frac{3}{4}$
170515	8"	8	16 $\frac{3}{8}$	11
170516**	12"	8	18 $\frac{1}{2}$	13

*Short Laying Length

** Southern Raised Head

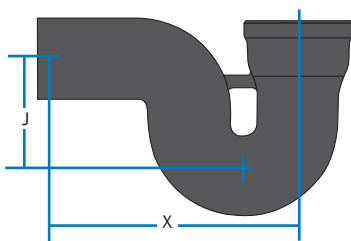

"P" TRAP

Part No.	Size	X	J
170525	2"	9 $\frac{1}{2}$	4
170526	3"	12	5 $\frac{1}{2}$
170527	4"	14	6 $\frac{1}{2}$
170528	6"	17	8 $\frac{1}{2}$
170529	8"	22 $\frac{1}{16}$	11 $\frac{1}{2}$



**EPOXY
SERVICE WEIGHT FITTINGS**

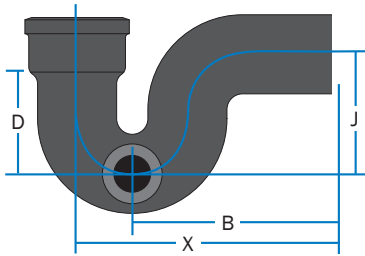

**“P” TRAP WITH CLEANOUT
RIGHT SIDE**

Part No.	Size	X	J	B	D
170536	4"	14	6½	11	5½

NOTE: 3½" IPS tap.

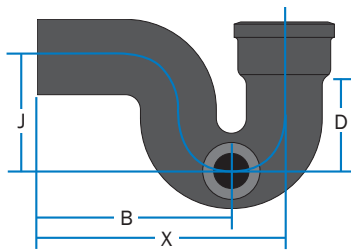

**“P” TRAP WITH CLEANOUT
LEFT SIDE**

Part No.	Size	X	J	B	D
170535	4"	14	6½	11	5½

NOTE: 3½" IPS tap.



EPOXY SERVICE WEIGHT FITTINGS

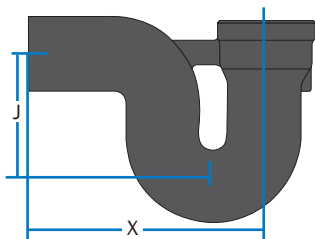

DEEP SEAL "P" TRAP

Part No.	Size	X	J
170540	2"	9½	6
170541	3"	12	7
170542	4"	14	8
170543	6"	17	9

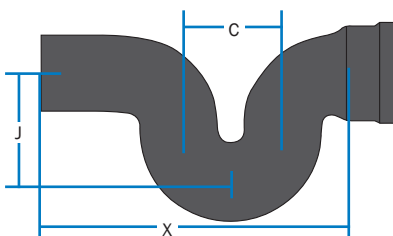

RUNNING TRAP

Part No.	Size	X	C	J
170550	4"	17½	6	6½
170551	6"	21½	8	8½



EPOXY SERVICE WEIGHT FITTINGS

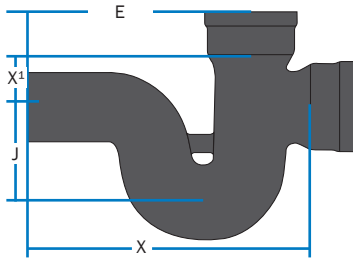

RUNNING TRAP w/ SINGLE HUB VENT

Part No.	Size	(Vent)	X	X'	J	E
170555	3"	(3)	15	2½	5½	12
170556	4"	(4)	17½	3	6½	14
170557	6"	(4)	21½	4	8½	15½
170558	8"	(6)	27⅝	5¾	11	11

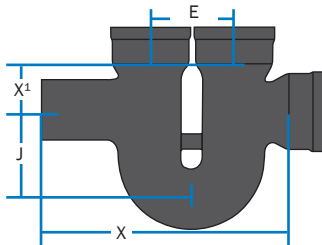

RUNNING TRAP w/ DOUBLE HUB VENTS

Part No.	Size	(Vent)	X	X'	E	J
170565	3"	(3-3)	15	2½	5	5½
170566	4"	(4-4)	17½	3	6	6½
170567	6"	(4-4)	21½	4	8	8½
170568	6"	(6-6)	21½	4	8	8½
170569	8"	(4-4)	27⅝	4	8	8½
170570	8"	(6-6)	27⅝	5¼	10	11
170571	10"	(8-8)	31⅝	6¼	12	13
170572	12"	(10-10)	38¾	7¼	15	15
170573	15"	(12-12)	45¾	8¾	18½	18½



EPOXY SERVICE WEIGHT FITTINGS

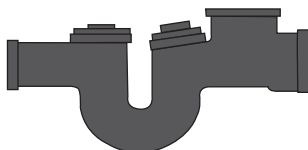

COMBINATION TRAP & TEE

Part No.	Size	Tap
170580	4 x 3"	3½"

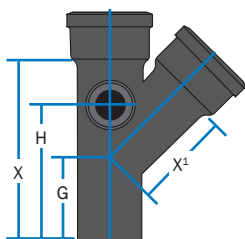

WYE w/ 2" SIDE OPENING

Part No.	Size	G	H	X	X¹
170620	4" LH	5¼"	10"	12"	6¾"
170621	4" RH	5¼"	19"	12"	5¾"

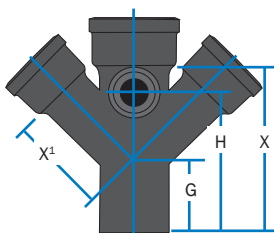

DOUBLE WYE W/ 2" SIDE OPENING

Part No.	Size	G	H	X	X¹
170630	4"	5¼"	10"	12"	9¼"



EPOXY SERVICE WEIGHT FITTINGS

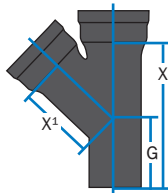

WYE

Part No.	Size	X	X'	G
170585	2"	8	4	4
170586	3 x 2"	9	5	4 ³ / ₁₆
170587	3"	10 ¹ / ₂	5 ¹ / ₂	5
170588	4 x 2"	9	5 ³ / ₄	3 ⁵ / ₈
170589	4 x 3"	10 ¹ / ₂	6 ¹ / ₄	4 ⁷ / ₁₆
170590	4"	12	6 ³ / ₄	5 ¹ / ₄
170614	5 x 2"	9	6 ¹ / ₂	3 ¹ / ₈
170615	5 x 3"	10 ¹ / ₂	7	3 ⁷ / ₈
170616	5 x 4"	12	7 ¹ / ₂	4 ¹ / ₁₆
170591	6 x 2"	9	7 ¹ / ₄	2 ⁹ / ₁₆
170592	6 x 3"	10 ¹ / ₂	7 ³ / ₄	3 ³ / ₈
170593	6 x 4"	12	8 ¹ / ₄	4 ³ / ₁₆
170617	6 x 5"	13 ¹ / ₂	8 ³ / ₄	4 ¹⁵ / ₁₆
170594	6"	15	9 ¹ / ₄	5 ³ / ₄
170595	8 x 4"	13 ¹ / ₂	9 ¹ / ₂	4 ³ / ₄
170618	8 x 5"	15	10	5 ¹ / ₂
170596	8 x 6"	16 ¹ / ₂	10 ¹ / ₂	6 ⁵ / ₁₆
170597	8"	19 ¹ / ₂	11 ¹ / ₁₆	7 ¹ / ₁₆
170598	10 x 3"	12	10 ³ / ₄	2 ³ / ₄
170599	10 x 4"	13 ¹ / ₂	11 ¹ / ₈	3 ⁹ / ₁₆
170600	10 x 6"	16 ¹ / ₂	12 ¹ / ₈	5 ¹ / ₈
170601	10 x 8"	19 ¹ / ₂	13 ⁷ / ₁₆	6 ¹ / ₂
170602	10"	22 ¹ / ₂	14 ¹ / ₂	8
170603	12 x 4"	15	12 ⁷ / ₁₆	4 ¹ / ₈
170604	12 x 6"	18	13 ⁷ / ₁₆	5 ¹ / ₁₆
170605	12 x 8"	21	14 ³ / ₄	7 ¹ / ₁₆
170606	12 x 10"	24	15 ¹ / ₁₆	8 ⁹ / ₁₆
170607	12"	27	16 ⁷ / ₈	10 ¹ / ₈
170608	15 x 4"	15 ¹ / ₄	15	2 ¹ / ₂
170609	15 x 6"	18	15 ³ / ₄	4
170610	15 x 8"	21	17 ¹ / ₁₆	5 ³ / ₈
170611	15 x 10"	24	18 ¹ / ₈	6 ⁷ / ₈
170612	15 x 12"	27	19 ³ / ₁₆	8 ⁷ / ₁₆
170613*	15"	31 ¹ / ₂	20 ³ / ₄	10 ³ / ₄

*XH only



EPOXY SERVICE WEIGHT FITTINGS

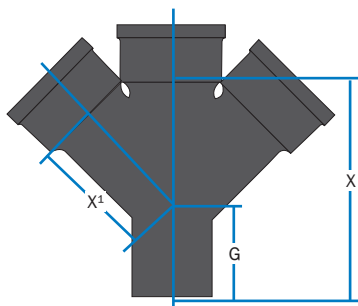

DOUBLE WYE

Part No.	Size	X	X'	G
170635	2"	8	4	4
170636	3 x 2"	9	5	4 ³ / ₁₆
170637	3"	10 ¹ / ₂	5 ¹ / ₂	5
170638	4 x 2"	9	5 ³ / ₄	3 ⁵ / ₈
170639	4 x 3"	10 ¹ / ₂	6 ¹ / ₄	4 ⁷ / ₁₆
170640	4"	12	9 ¹ / ₄	5 ¹ / ₄
170641	6 x 3"	10 ¹ / ₂	7	3 ³ / ₈
170642	6 x 4"	12	8 ¹ / ₄	4 ³ / ₁₆
170643	6"	15	9 ¹ / ₄	5 ³ / ₄
170644	8 x 4"	13 ¹ / ₂	9 ¹ / ₂	4 ³ / ₄
170645	8 x 6"	16 ¹ / ₂	10 ¹ / ₂	6 ⁵ / ₁₆
170646	8"	19 ¹ / ₂	11 ¹³ / ₁₆	7 ¹ / ₁₆
170647	10 x 6"	19 ¹ / ₂	12 ¹ / ₈	5 ¹ / ₈
170648	10 x 8"	19 ¹ / ₂	13 ⁷ / ₁₆	6 ¹ / ₂
170649	10"	22 ¹ / ₂	14 ¹ / ₂	8
170650	12 x 8"	21	14 ³ / ₄	7 ¹ / ₁₆
170651	12"	27	16 ⁷ / ₈	10 ¹ / ₈
170652*	15"	31 ¹ / ₂	20 ³ / ₄	10 ³ / ₄

*XH only



EPOXY SEARCH INVENTORY

SEARCH INVENTORY

For all soil pipe products, 24 hours a day, 7 days a week.

Stock check now takes just seconds. You can use either the part numbers in the Price Sheets, or search by product description.

Scan the QR Code
to view our inventory





STANDARDS & SPECIFICATIONS

STANDARDS & SPECIFICATIONS

Piping to be installed for the various services shall be as specified or in accordance with local plumbing codes:

NO-HUB® Cast Iron Soil Pipe and Fittings:

- CISPI 301 (Cast Iron Soil Pipe Institute)
- ASTM A 888 (American Society for Testing and Materials)

NO-HUB® Couplings:

- CISPI 310 (Cast Iron Soil Pipe Institute)
- ASTM C 1277 (American Society for Testing and Materials)
- ASTM C 1540 (American Society for Testing and Materials)

SV Hub and Spigot Cast Iron Soil Pipe and Fittings:

- ASTM A 74 (American Society for Testing and Materials)

Hub & Spigot Gaskets:

- ASTM C 564 (American Society for Testing and Materials)



DURA PIPE™ ENHANCED EPOXY COATED CAST IRON PIPE & FITTINGS

DuRa Pipe™ is an enhanced epoxy coating applied to cast iron soil pipe and fittings made in the U.S.A. DuRaPipe™ is well-suited for aggressive DWV applications where greater performance is required. This is not an equivalent or viable option for acid waste pipe.

Standard cast iron pipe and fittings perform exceptionally well in most applications. However, the DuRa Pipe™ enhanced epoxy coated cast iron solution offers significant advantages for aggressive applications.

- Commercial Kitchens
- Hospitals and Medical Office Buildings
- Casinos
- Soda Fountains
- Seasonal Occupancy Buildings
- Any area with exposure to chemicals from pH 2 to pH 12

DuRa Pipe™ enhanced epoxy coating begins with the same high quality cast iron pipe we have always made. However, instead of being dipped in an asphalt coating, the pipe is coated inside and out with a two-component, solvent free, epoxy that provides additional protection against corrosive environments.



DURA PIPE™ ENHANCED EPOXY COATED CAST IRON PIPE & FITTINGS

Fittings are fully coated with a fusion bonded epoxy that provides the same additional protection against corrosive environments. DuRa Pipe™ is available in ranges from 2” to 15” No-Hub and Hub & Spigot (Service Weight) in 10’ lengths.

These products conform to ASTM A 74, ASTM A 888, CISPI 301 standards. It is certified by NSF International complying with performance and quality requirements of all standards.

For Installation guide, please reference the following:

<https://www.tylerpipe.com/resources/technical-data/installation-guides/>

Where an on-site coating of the cut edges is desired or specified, it is recommend the use of PPG Multi-Prime 4160 or Fast Dry 4190. In areas where a low VOC is required, it is recommended the use of PPG Amerlock 2. Follow the instructions on the data sheets provided in the links below.

Multi-Prime 4160:

<https://www.ppgpmc.com/products/MULTIPRIME-4160>

Fast Dry4190:

<https://www.ppgpmc.com/products/fast-dry-4190>

Amerlock 2:

<https://www.ppgpmc.com/products/amerlock-2-sigma-cover-2>



DURA PIPE™ NO-HUB SUBMITTAL

SPECIFICATIONS

All drain, waste, vent, sewer and storm lines shall be of cast iron soil pipe, fittings, and couplings. It shall be NSF certified to conform to the CISPI 301 standard and comply with ASTM A 888, latest edition. Pipe and fittings shall be marked with the collective trademarks of the Cast Iron Soil Pipe Institute and NSF International, indicate the manufacturer's name, country of origin and date of manufacture, or receive prior approval of the engineer.

STANDARDS

CISPI 301: Hubless Cast Iron Soil Pipe & Fittings

ASTM A 888: Hubless Cast Iron Soil Pipe & Fittings

ASTM C 564: Rubber Gaskets for Cast Iron Soil Pipe & Fittings

NOTE: Tyler Pipe strongly recommends that its hubless cast iron soil pipe & fittings be joined with shield couplings manufactured in accordance with CISPI 301. The use of unshielded couplings or any coupling not meeting the above specifications will void the product warranty.



DURA PIPE™

NO-HUB SUBMITTAL

NO-HUB PIPE, TEN-FOOT LAYING LENGTH

Size	Wt. per 10* lbs.	Per Bundle	
		Pieces	Wt. lbs.
1½	30	54	1620
2	36	64	2304
3	52	48	2496
4	74	30	2220
5	94	24	2256
6	110	21	2310
8	180	15	2700
10	258	8	2064
12	325	6	1950
15	497	3	1416

*Note: Weights approximate, for shipping purposes only



NO-HUB, TEN-FOOT LAYING LENGTH DIMENSIONS AND TOLERANCES

Size	Hubless Pipe Barrels			
	B Inside Diameter	J Outside Diameter	T Thickness	
			Nom.	Min.
1½	1.50±.09	1.90±.06	.16	.13
2	1.96±.06	2.35±.09	.16	.13
3	2.96±.06	3.35±.09	.16	.13
4	4.00±.06	4.38+.09-.05	.19	.15
5	4.94±.09	5.30+.09-.05	.19	.15
6	5.94±.09	6.30+.09-.05	.19	.15
8	7.94±.13	8.38+.13-.09	.23	.17
10*	10.00±.13	10.56±.09	.28	.22
12	11.94±.09	12.50±.09	.28	.22
15	15.11±.09	15.83±.09	.36	.30

O.D. Barrel out of round tolerance of ±.04 is permitted.



DURA PIPE™ NO-HUB SUBMITTAL

SPECIFICATIONS

This document is to certify that products manufactured by McWane Plumbing Group are manufactured in the United States and conform to the following standards:

DuRa Pipe™ No-Hub Pipe & Fittings

- Cast iron soil pipe and fittings shall be marked with the trademark of the Cast Iron Soil Pipe Institute (CISPI).
- ASTM A 888
- Meets the UP Code

No-Hub Couplings

- Cast Iron Soil Pipe Institute Standard 310
- ASTM C 1277
- Certified by NSF International

No-Hub Heavy Duty Couplings

- ASTM C 1540
- Factory Mutual 1680
- Certified by NSF International

McWane Plumbing Group products are manufactured to all applicable ASTM standards. McWane Plumbing Group will not accept responsibility for other cast iron products performance, dimensional accuracy, or compatibility of pipe, fittings, gaskets, or couplings that are not manufactured or sold by McWane, Inc.



DURA PIPE™ NO-HUB SUBMITTAL

INDUSTRY REFERENCE STANDARDS FOR CAST IRON PIPE & FITTINGS

AMERICAN SOCIETY FOR TESTING AND MATERIALS

A 888: Specification for hubless cast iron soil pipe and fittings.

Scope: This specification covers cast iron pipe and fittings used in sanitary drain, waste, and vent (DWV), sewer and storm drainage applications. This system is intended only for non-pressure applications.

C 564: Specification for rubber gaskets for cast iron soil pipe and fittings.

Scope: This specification covers pre-formed rubber gaskets used to seal joints in cast iron soil pipe and fittings.

C 1277: Specification for coupling for use in connection with hubless cast iron pipe and fittings for sanitary and storm drain, waste, and vent (DWV) piping application (regular hubless coupling).

Scope: The purpose of this specification is to establish criteria for material dimensions and tolerances for one type of coupling used in hubless cast iron soil pipe and fittings for sanitary and storm drain, waste, and vent (DWV) piping applications.



DURA PIPE™ NO-HUB SUBMITTAL

AMERICAN SOCIETY FOR TESTING AND MATERIALS

C 1540: Specification for shielded couplings joining hubless cast iron soil pipe and fittings (heavy duty couplings).

Scope: This specification covers pre-formed rubber gaskets used to seal joints in cast iron soil pipe and fittings.

CAST IRON SOIL PIPE INSTITUTE

301: Specification for hubless cast iron soil pipe and fittings for sanitary and storm drain, waste, and vent (DWV) piping applications.

Scope: The purpose of this standard is to establish standards covering material, dimensions, and tolerance for pipe and fittings for hubless cast iron sanitary and storm drain, sanitary waste, and vent (DWV) piping applications.

310: Specification for coupling for use in connection with hubless cast iron pipe and fittings for sanitary and storm drain, waste, and vent (DWV) piping application (regular hubless coupling).

Scope: The purpose of this specification is to establish criteria for material dimensions and tolerances for one type of coupling used in hubless cast iron soil pipe and fittings for sanitary and storm drain waste, and vent (DWV) piping applications



DURA PIPE™ HUB & SPIGOT SUBMITTAL

SPECIFICATIONS

All 2 inch through 15 inch hub & spigot cast iron soil pipe and fittings shall conform to ASTM A 74; joints shall be made either by caulked lead and oakum or by compression gaskets such as TY-Seal which conforms to ASTM C 564.

STANDARDS

ASTM A 74: Cast Iron Soil Pipe & Fittings

ASTM C 564: Rubber Gaskets for Cast Iron Soil Pipe & Fittings

SV Hub & Spigot and Fittings

Size	Y	A	C	J	B	T	Min. T
2	2.50	2.94	3.62	2.30	1.96	0.17	0.14
3	2.75	3.94	4.68	3.30	2.96	0.17	0.14
4	3.00	4.94	5.68	4.30	3.94	0.18	0.15
5	3.00	5.94	6.68	5.30	4.94	0.18	0.15
6	3.00	6.94	7.68	6.30	5.94	0.18	0.15
8	3.50	9.25	10.13	8.38	7.94	0.23	0.17
10	3.50	11.38	12.44	10.50	9.94	0.28	0.22
12	4.25	13.50	14.56	12.50	11.94	0.28	0.22
15	4.25	16.95	18.11	15.88	15.16	0.36	0.33

NOTE: All drain, waste, vent, sewer and storm lines shall be of cast iron soil pipe & fittings. It shall conform to CISPI HS-74, ASTM A 74, & ANSIA-112.5.1, latest editions. Pipe and fittings shall be marked with the collective trademarks of CISPI & NSF. It shall state the manufacturer's name, country of origin, and date of manufacturer (for pipe), or receive prior approval of the engineer.



DURA PIPE™ HUB & SPIGOT SUBMITTAL

SPECIFICATIONS

This document is to certify that products manufactured by McWane Plumbing Group are manufactured in the United States and conform to the following standards:

DuRa Pipe™ Service Hub & Spigot Pipe & Fittings

- Cast iron soil pipe and fittings shall be marked with the trademark of the Cast Iron Soil Pipe Institute (CISPI).
- ASTM A 74
- Meets the UP Code

Compression Gaskets

- ASTM C 564
- CISPI HSN 85

McWane Plumbing Group products are manufactured to all applicable ASTM standards. Tyler Pipe will not accept responsibility for other cast iron products performance, dimensional accuracy, or compatibility of pipe, fittings, gaskets, or couplings that are not manufactured or sold by McWane, Inc.

Note: All dimensions & tolerances for Extra Heavy Cast Iron Pipe & Fittings are published individually.



DURA PIPE™ HUB & SPIGOT SUBMITTAL

INDUSTRY REFERENCE STANDARDS FOR CAST IRON PIPE & FITTINGS

AMERICAN SOCIETY FOR TESTING AND MATERIALS

A 74: Specification for hubless cast iron soil hub & spigot pipe & fittings (service & extra heavy)

Scope: The specification covers cast iron pipe & fittings used in sanitary drain, waste, and vent (DWV) sewer, and storm drainage applications.

C 564: Specification for rubber gaskets for cast iron soil pipe and fittings.

Scope: This specification covers pre-formed rubber gaskets used to seal joints in cast iron soil pipe and fittings.



HUSKY CR 7000 HEAVY DUTY CORROSION RESISTANT 316 SS NO-HUB COUPLING SUBMITTAL

CERTIFICATION

Tested & Certified to:

ASTM C 1540

ASTM C 564

CSA B602

IAMPO File 6726



MATERIAL SPECIFICATIONS

Clamp: Type 316 AISI stainless steel

Screw: Type 316 AISI

Shield: Type 316 AISI stainless steel, corrugated.

Shield thickness 0.015

Gasket: The gasket shall be manufactured from a properly vulcanized virgin compound in which the primary elastomer is polychloroprene (neoprene) conforming to ASTM C 564. Oil Immersion test: 80% max. Volume Change after immersion in IRM 903 for 70 hours at 212 F.

Size	Width	No. of Straps	Torque
1.5" - 4"	3.0	4	80
5" & 6"	4.0	6	80
8" & 10"	4.0	6	80





HUSKY CR 7000 HEAVY DUTY CORROSION RESISTANT 316 SS NO-HUB COUPLING SUBMITTAL

The Husky CR 7000 Corrosion Resistant Coupling has been engineered by Anaco to provide a heavy-duty 316 stainless steel coupling for corrosive applications, balancing the desire for a more rigid joint with the need to provide a superior positive seal, which can accommodate possible disparities in the No-Hub pipe and fittings. This has been accomplished by manufacturing our coupling with a heavy-duty corrugated shield of sufficient width to accommodate additional surface-bearing sealing clamps.

The additional sealing clamps when torqued to 80-inch pounds, offer two salient performance related features. First, the overall dimensional thickness of the clamp and shield, in conjunction with the additional width of the coupling, result in a more uniformly rigid joint, with the load being supported at both the outer edge of the coupling and the centerline of the joint. Second, the additional sealing clamps yield increased surface-bearing contact between the coupling and the pipe or fittings, thereby inhibiting joint movement at higher internal pressures not commonly associated with a DWV system.

The 1.5" through 4" diameter couplings consist of a 3" wide corrugated 316 stainless steel shield in conjunction with four (4) 316 stainless steel clamps, secured in place by means of an affixed and "floating" eyelet to allow the clamp "travel" during tightening.

The 5" through 10" diameter couplings consist of a 4" wide corrugated 316 stainless steel shield in conjunction with six (6) 316 stainless steel clamps, secured in place by means of an affixed and "floating" eyelet to allow the clamp "travel" during tightening.

All Husky CR 7000 Corrosion Resistant Couplings are designed to be installed with a pre-set torque wrench calibrated at 80-inch pounds to accommodate the 3/8" Hex Head screw.



INSTALLATION SUGGESTIONS HUSKY CR 7000 HEAVY DUTY CORROSION RESISTANT 316 SS NO-HUB COUPLING

PURPOSE

These suggestions provide guidelines for the use of Anaco HUSKY® CR 7000 Coupling for joining No-Hub pipe and fittings in accordance with accepted industry standards and practices. All construction projects involve many variables. Governing codes, engineering criteria, and the conventions of the plumbing trade necessitate that judgment decisions must be a combination of design and “on the job” considerations. The following suggestions for joining No-Hub pipe and fittings with the Anaco Husky CR 7000 coupling are not definitive but it is hoped that they will be helpful.

INSTALLATION INSTRUCTIONS

A properly calibrated torque wrench set at 80-inch pounds to accommodate the 3/8” hex head screw should always be used when installing HUSKY® CR 7000 couplings. When power tools are used to install HUSKY couplings they should be adjusted or calibrated to torque only to 80-inch pounds.

1-1/2” thru 4”

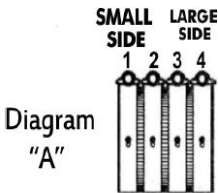

5” thru 10”

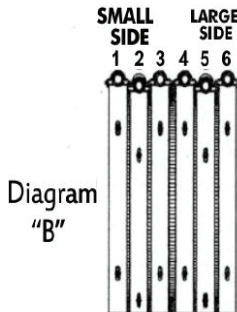



INSTALLATION SUGGESTIONS HUSKY CR 7000 HEAVY DUTY CORROSION RESISTANT 316 SS NO-HUB COUPLING

1. In order to provide a sound joint with field cut lengths of pipe, the ends should be cut square. Place the neoprene gasket on the end of one pipe and the stainless steel clamp assembly on the other end of the other pipe or fitting to be joined.
2. Firmly seat both ends of the pipe/fittings against the internally molded shoulder in the center of the gasket.
3. Slide the clamp assembly into position centered over the gasket.
4. HUSKY CR 7000 couplings 1.5", 2", 3" and 4" are three inches wide and have four sealing bands. Tighten bands to 80-inch pounds in the following sequence. Starting on the side of the joint with the smaller OD (see diagram "A") torque as follows: 2, 1 - 2,1 - 3,4 - 3,4 - 2,1 - 3,4
5. HUSKY CR 7000 couplings 5"-10" are four inches wide, 12" and 15" are 5½" wide and have six sealing bands. Tighten bands to 80-inch pounds in the following sequence. Starting on the side of the joint with the smaller OD (see diagram "B") torque as follows: 3,21 - 3,2,1 - 4,5,6 - 4,5,6 - 2,1 - 4,5,6.
6. Typically, once the coupling is installed and torqued to 80-inch pounds in this torque pattern, this is all that is necessary. Couplings may be re-torqued to confirm that all bands have been properly torqued to 80-inch pounds, following the proper torque pattern. Use caution as multiple torquing events may result in clamp failure.



INSTALLATION SUGGESTIONS HUSKY CR 7000 HEAVY DUTY CORROSION RESISTANT 316 SS NO-HUB COUPLING

BRACING

Horizontal pipe and fittings five inches and larger must be suitably braced to prevent horizontal movement. This must be done at every branch opening or change of direction by the use of braces, blocks, rodding or other suitable method to prevent movement or joint separation. (Chapter IV, Handbook of Cast Iron Soil Pipe Institute).

Anaco has intentionally color coated the HUSKY® CR 7000 304 Stainless Steel Shield. The black shield identifies this product as a genuine Anaco HUSKY CR 7000 Heavy-Duty coupling. HUSKY's performance, including its exceptional sealing ability, corrosion resistance, deflection and rigidity has not been compromised in any way.



INSTALLATION GUIDE HUB & SPIGOT

MATERIALS NEEDED

Proper, approved equipment and attire:

- DuRa Pipe™ cast iron soil pipe and fittings
- TY-Seal® or EZ-Tight® Gaskets
- TY-Seal® Lube or Lubri/Fast® Adhesive Lubricant
 - TY-Seal Lube® for sizes 2 inches through 4 inches
 - Lubri/Fast® Adhesive Lube for sizes 5 inches through 15 inches
 - Brush for lubricant application

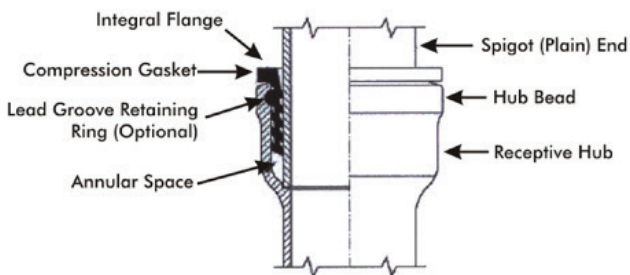

Note: All gaskets specified meet or exceed the requirements of ASTM C564 and ASTM C1553



INSTALLATION GUIDE

HUB & SPIGOT

INSTALLATION

1. Clean the hub and pipe or fitting end to be joined. They should be free of dirt, mud, gravel, or other foreign material.
2. Insert the gasket into the hub. When joining 5 inches or larger pipe and fittings, apply Lubri/Fast® Adhesive Lubricant to the inside surface of the hub before inserting the gasket.
3. Lubricant the inside surfaces of the gasket and the outside of the spigot end to be joined using a brush. (Use TY-Seal® Lube for sizes 2 inches through 4 inches. Use Lubri/Fast® Adhesive Lubricant for sizes 5 inches through 15 inches).
4. Align the pipe and/or fittings to be joined. Push or pull the pipe or fitting spigot into the hub. You will feel the pipe or fitting “bottom out” at the hub. The assembly tool of your choice may be used.

Note: If joining a cut piece of pipe, the sharp edges of the pipe must be “peened” with a hammer or filed to remove the sharp edge. Failure to remove the sharp edge on cut pipe will make assembly difficult.



INSTALLATION GUIDE CUTTING INSTRUCTIONS

Cast Iron Soil Pipe may vary somewhat in toughness and resiliency. Usually, best cuts are made by using a twin-lever snap cutter or a ratchet type cutter equipped with a chain and equally spaced beveled cutting wheels.

Cutting Procedure:

1. Position chain around pipe so that the maximum number of wheels are in contact with the pipe. Excessive space between the first and last wheel in contact with the pipe is almost certain to produce a poor quality cut.
2. Score the pipe before the final pressure is applied to complete the cut. Apply only enough pressure to make the cutter wheel indent the pipe.
3. Release the pressure and rotate tool a few degrees; then apply a quick final pressure to complete the cut. If a piece of pipe is unusually tough, score the pipe several times and a good cut can be made.

Note: If the cutter wheels become flattened or dull, it will be very difficult (if not impossible) to obtain a satisfactory cut. The life of the chain can be extended by reversing the chain to obtain equal use of all wheels. It is also important to keep the mechanical features of a cutter in good working order.



INSTALLATION GUIDE CAULKING INSTRUCTIONS

1. Insert the spigot end of pipe or fitting into the hub of pipe or fitting to be joined after wiping the hub and spigot with a clean cloth to assure the hub and spigot are clean and dry.

2. Yarn the oakum into the joint using a yarning iron. Some oakum comes in twisted lengths and may need to be separated into individual strands before yarning. Yarn and pack the oakum tightly using a packing iron to a depth of one inch below the top of the joint. Tightly packed oakum is essential for a leak free joint.

Note: After packing, make sure that no oakum fibers are sticking up into the area the lead will occupy. Fibers in the lead area can cause leaks.

3. After heating lead pot to a cherry red color, clean dross off the top of the lead and fill your ladle with clean, molten lead. Quickly pour the lead into the joint with one continuous pour, filling the joint completely.

4. After the lead has solidified, the joint must be caulked to “set” the lead. Using your outside caulking iron, place the iron against the inner edge of the hub and caulk the lead completely around the circumference of the joint. After caulking with the outside iron, you are ready to caulk using the inside iron. The inside iron should be placed against the pipe. Caulk the lead completely around its circumference.

Note: Care should be taken to not crack the hub by caulking to heavily. Proper safety equipment and attire are required. Tyler Pipe does not recommend the use of lead as it has been found to be hazardous to health and the environment.



DURA PIPE EPOXY COATED CAST IRON FOR DWV PLUMBING SYSTEMS:

- **NO-HUB PIPE & FITTINGS**
- **HUB & SPIGOT PIPE & FITTINGS**
- **TECHNICAL INFORMATION**
- **SUBMITTAL DATA**



McWane Plumbing Group

11910 County Road 492 ▪ Tyler, TX 75706

800.527.8478 ▪ TylerPipe.com