

**DUCTILE IRON PIPE JOINTS  
AND THEIR USES**

**DIPRA  
DIPRA  
DIPRA  
DIPRA**



# Ductile Iron Pipe Joints and Their Uses

By Richard W. Bonds, P.E.  
DIPRA Research and Technical Director

## Introduction

Joints for Iron pipe have come a long way. About 550 years ago, the first Cast Iron pipes were made with flanged joints, using lead or leather gaskets. The bell and spigot joint, which was assembled by caulking yarn or braided hemp into the base of the annular bell cavity and then pouring molten lead into the remaining space inside the bell, was developed in 1785 and extensively used until the late 1950s. The roll-on joint was developed in 1937 and was used for roughly 20 years before its manufacture was discontinued. Assembly of this joint involved a compressed rubber gasket rolled under a restriction ring, followed by caulked square-braided jute. The remainder of the joint was packed with a bituminous compound.

Today, the push-on and mechanical joints are the most prominent. The mechanical joint was developed for gas industry use in the late 1920s but has since been used extensively in the water industry. The push-on joint was developed in 1956 and represented an important advancement in the water distribution field.

Several special joints have been available for years. These include ball and socket for subaqueous crossings, grooved and shouldered, and numerous variations of restrained joints.

There is a much wider variety of joints available for Ductile Iron pipe than any other piping material, providing greater flexibility and versatility in pipeline design and installation.

## Push-On Joints

The most popular, quickest, and easiest-to-assemble joint for Ductile Iron pipe and fittings in underground applications is the push-on joint. This joint consists of a single rubber gasket placed in a groove inside the socket at the bell end of the pipe. After lubricating the joint in accordance with the manufacturer's instructions, the beveled end of the pipe is pushed past the gasket, compressing it and forming a pressure-tight and dependable seal. Step-by-step installation procedures can be found in ANSI/AWWA C600 "Installation of Ductile-Iron Water Mains and Their Appurtenances." Assembly of the push-on joint is simple and fast. Large bell holes are not required for this joint, and it can be assembled under wet-trench conditions or even underwater. The push-on joint has been tested to more than 1,000 psi internal pressure, 430 psi external pressure and 14 psi negative air pressure with no leakage or infiltration. Push-on joints of modern Ductile Iron pipe systems are particularly effective in preventing problems of infiltration, exfiltration, and root intrusion that have plagued sewer systems of other piping materials. Push-on joint performance requirements and push-on gasket manufacturing and performance requirements have been included in ANSI/AWWA C111/A21.11 "American National Standard for Rubber-Gasket Joints for Ductile-Iron Pressure Pipe and Fittings" for many years.

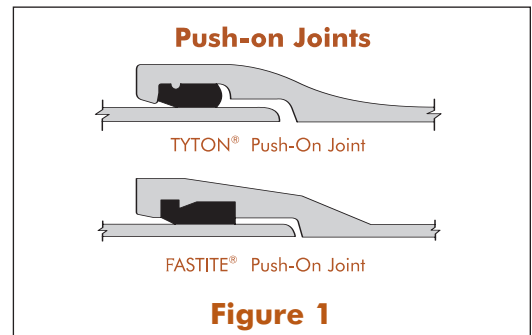

Figure 1

There are two types of push-on joints: the FASTITE<sup>®1</sup> and TYTON<sup>®2</sup> joints, which are shown in Figure 1. They differ somewhat in configuration, but both feature a gasket recess that is integrally cast into the bell of the pipe. The compression of the standard dual-hardness gasket results from the spigot being pushed home. The result is a flexible joint that is easy to assemble. Furthermore, the gasket is not easily dislodged or "rolled" during installation. Depending on pipe diameter, push-on joint Ductile Iron pipe has a joint deflection of up to 5° (Figure 2 and Table 1). This deflection enables the pipeline to be diverted from a straight line when following the curvature of streets and roads or when avoiding obstacles.

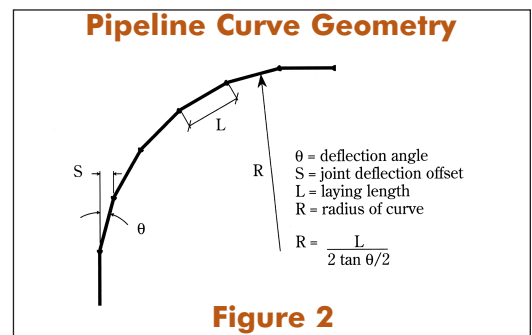

Figure 2

On long radius curves, the trench should be excavated wider than normal to allow for straight line assembly before deflection. Inserting the plain end of a full length of pipe into a socket under deflected conditions is not recommended and should be avoided if possible. When deflection is necessary, pipe should be assembled in a straight line, both horizontally and vertically, before deflection is made.

<sup>1</sup> FASTITE<sup>®</sup> is a registered trademark of American Cast Iron Pipe Company. <sup>2</sup> TYTON<sup>®</sup> is a registered trademark of United States Pipe and Foundry Company.

## Mechanical Joint

The mechanical joint has standardized dimensions as specified in ANSI/AWWA C111/A21.11 “Rubber-Gasket Joints for Ductile-Iron Pressure Pipe and Fittings.” It is available for 3-inch through 24-inch-diameter Ductile Iron pipe manufactured in accordance with ANSI/AWWA C151/A21.51, and 3-inch through 48-inch fittings manufactured in accordance with ANSI/AWWA C110/A21.10 and C153/A21.53. The mechanical joint uses the basic principle of the stuffing box and gland developed nearly 100 years ago.

The joint has four parts: a flange cast with a bell; a rubber gasket that fits in the bell socket; a gland, or follower ring, to compress the gasket; and tee head bolts and nuts for tightening the joint (Figure 3). Joint assembly is labor-intensive but very simple and requires only one tool — an ordinary ratchet wrench. Step-by-step installation procedures can be found in ANSI/AWWA C600. The mechanical joint is flexible, with the amount of deflection dependent on pipe diameter (Table 2 and Figure 2). The mechanical joint is used mainly with fittings rather than pipe. This is due to the predominant use of push-on joints, which are more economical, faster to install, more trouble-free, and offer better service than mechanical joints.

Lubrication of the plain end, socket, and gasket during assembly of mechanical joint Ductile Iron pipe is recommended in ANSI/AWWA C111/A21.11, ANSI/AWWA C600, and manufacturers’ literature. Based on controlled testing and extensive field experience, DIPRA concurs with this recommended lubrication with soapy water or approved pipe lubricant during mechanical joint assembly to improve gasket sealing and long-term performance.

## Flanged Joint

Although the flanged joint’s first recorded application was more than 550 years ago, improved joints of this type are still used for many aboveground plant installations and other specialized applications (Figure 4). Flanged-joint Ductile Iron pipe is manufactured in accordance with ANSI/AWWA C115/A21.15 and is available in 3-inch through 64-inch diameters. Flanged fittings for 3-inch through 48-inch are manufactured in accordance with ANSI/AWWA C110/A21.10 and 54-inch through 64-inch are manufactured in accordance with ANSI/AWWA C153/A21.53.

Flanged joints for Ductile Iron pipe and fittings are rated for 250 psi working pressure. However, in accordance with ANSI/AWWA C111/A21.11, 24-inch and smaller flanged joints with Ductile Iron flanges may be rated for a maximum working pressure of 350 psi with the use of special gaskets.

Flanged piping systems should be installed in accordance with the suggested procedures listed in the appendices of ANSI/AWWA C110/A21.10, C115/A21.15 and C153/A21.53 Standards. Questions concerning gaskets should be directed to the manufacturer. For compatibility of these flanges with other standards, see DIPRA’s brochure “Flanged Ductile Iron Pipe and Fittings.”

**Table 1**

Nominal Pipe Size (in.)	Deflection Angle - $\theta^*$ (deg.)	Max. Offset - S* (in.)		Approx. Radius of Curve - R* Produced by Succession of Joints (ft.)	
		L* = 18 ft.	L* = 20 ft.	L* = 18 ft.	L* = 20 ft.
3	5	19	21	205	230
4	5	19	21	205	230
6	5	19	21	205	230
8	5	19	21	205	230
10	5	19	21	205	230
12	5	19	21	205	230
14	3	11	12	340	380
16	3	11	12	340	380
18	3	11	12	340	380
20	3	11	12	340	380
24	3	11	12	340	380
30	3	11	12	340	380
36	3	11	12	340	380
42	3	11	12	340	380
48	3	-	12	-	380
54	3	-	12	-	380
60	3	-	12	-	380
64	3	-	12	-	380

Note: For 14-inch and larger push-on joints, maximum deflection may be larger than shown above. Consult your DIPRA member company.  
\* See Figure 2

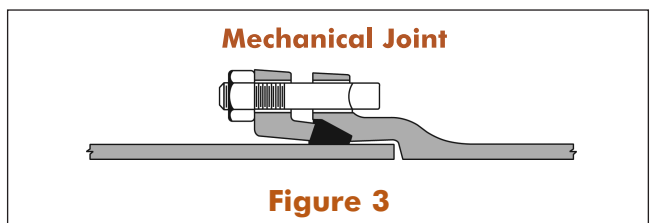
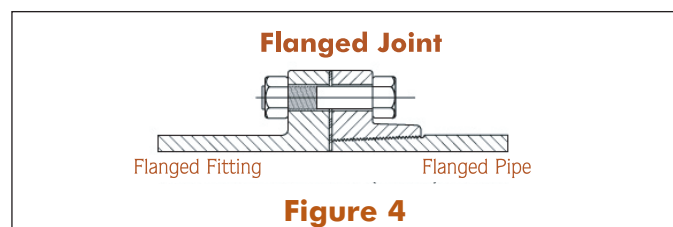

**Table 2**

Nominal Pipe Size (in.)	Deflection Angle† - $\theta^*$ (deg.)	Max. Offset - S* (in.)		Approx. Radius of Curve - R* Produced by Succession of Joints (ft.)	
		L* = 18 ft.	L* = 20 ft.	L* = 18 ft.	L* = 20 ft.
3	8	31	35	125	140
4	8	31	35	125	140
6	7	27	30	145	160
8	5	20	22	195	220
10	5	20	22	195	220
12	5	20	22	195	220
14	3.5	13.5	15	285	320
16	3.5	13.5	15	285	320
18	3	11	12	340	380
20	3	11	12	340	380
24	2	9	10	450	500

† Rounded down to nearest half degree.

\* See Figure 2



## Restrained Joints

One big advantage of Ductile Iron pipe systems vs. alternate materials is the vast amount and variety of thrust restraint joint options. These restrained joints are used to resist thrust forces as an alternative to thrust blocking. A restrained joint is a special type of push-on or mechanical joint that is designed to provide longitudinal restraint. Restrained joint systems function in a manner similar to thrust blocks, insofar as the reaction of the entire restrained unit of piping with soil balances the thrust force. These special joints offer flexibility and are simply and quickly installed. Each manufacturer of Ductile Iron pipe holds patents on its own unique designs of these joints, and, therefore, the majority of restrained joints are considered proprietary.

Restrained joints are rated up to 350 psi working pressure for 4-inch- through 24-inch-diameter Ductile Iron pipe, and up to 250 psi working pressure for 30-inch through 64-inch. In some cases, restrained joints have been furnished for applications with far greater pressures. It is recommended that the manufacturer be consulted in such cases.

### Push-On Restrained Joints

Push-on restrained joints are available in two basic types of designs: those with restrained push-on gaskets and specially designed push-on restrained joints.

#### Restrained Push-On Gasket

Restrained push-on gaskets have proven to be an extremely successful, trouble-free means of joint restraint for Ductile Iron pipe. These are patented gaskets that contain high-strength stainless steel elements spaced around the gasket that develop a dependable gripping action. Because of the wedging design, the force between the spigot and the socket of the pipe joint is essentially constant at any given pressure thrust regardless of the tightness or looseness of the joint fit or the joint deflection. Two configurations of this joint are shown in Figure 5.

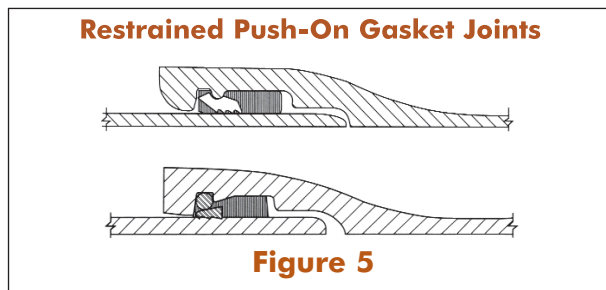

These push-on restrained joint gaskets are available for 4-inch through 30-inch-diameter Ductile Iron pipe. They are suitable for an allowable working pressure of up to 350 psi for 4-inch through 24-inch-diameter pipe and 150 psi for 30-inch.

These special gaskets are available for both the FASTITE® and TYTON® push-on joints. They have the same basic shape as the FASTITE® and TYTON® regular gaskets, so they can be used in any standard FASTITE® and TYTON® joint pipe. Therefore these gaskets may be used in lieu of standard push-on gaskets in the bells of standard push-on joint pipe, fittings, and valves where easy, field-adaptable restraint is desired. Note: FASTITE® and TYTON® gaskets, both standard and restrained gaskets, are not interchangeable.

Assembly is very similar to that of regular push-on joint pipe. Pipe cut in the field must be properly prepared prior to assembly. Contact pipe manufacturers for details on assembly and preparation of cut pipe.

#### Specially Designed Push-On Restrained Joints

Specially designed push-on restrained joints incorporate a push-on gasket and special bell designs in conjunction with their restraint mechanisms. The push-on gaskets used in these joints might not be interchangeable with the standard push-on gaskets. Contact the pipe manufacturer for details. Five configurations of this type joint are shown in Figure 6.

These types of specially designed push-on restrained joints are available for 4-inch- through 64-inch-diameter Ductile Iron pipe. They are suitable for an allowable working pressure of up to 350 psi for 4-inch- through 24-inch-diameter pipe and 250 psi for 30-inch through 64-inch.

In general, this type of joint is easily assembled by making a conventional push-on joint assembly and then inserting the Flex-Ring®, split ring, or ring segments (depending on design), extending the joint to remove any slack in the locking mechanism, and then setting the joint deflection as required. Each pipe manufacturer produces its own proprietary joints that have explicit installation instructions.

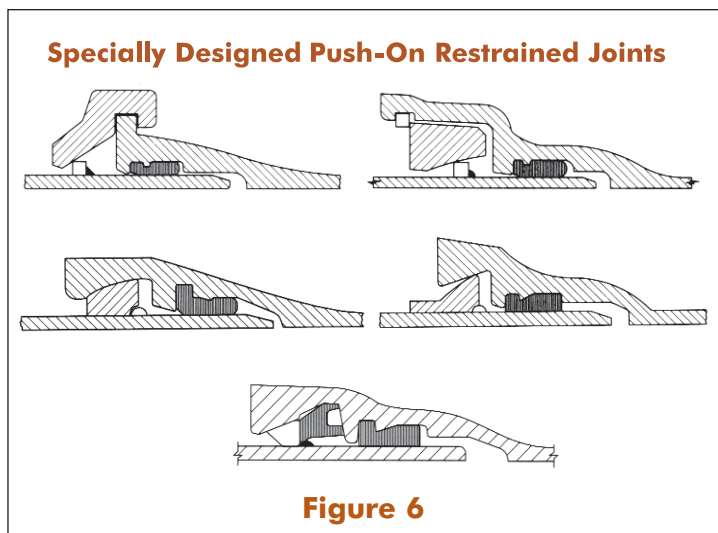

## Mechanical Restrained Joints

Mechanical restrained joints offer a method of providing joint restraint with a standard mechanical joint socket of a pipe, fitting, valve, or other product. With the exception of some set-screw retainer glands, the tee-bolts for these joints are not standard length; special-length bolts are required for these joints. Three configurations of this type joint are shown in Figure 7.

## Field-Welded Restrained Joints

Some restrained joints (push-on and mechanical) have a Ductile or alloy steel retainer ring welded around the circumference of the spigot of the pipe to provide a means of restraint. If one of these types of restrained joint pipe had to be cut in the field, a new ring would be required to be field welded around the new cut spigot. DIPRA and the manufacturers of Ductile Iron pipe offer technical papers outlining the procedure whereby Ductile Iron or alloy steel rings can be field welded onto the barrels of Ductile Iron pipe to be used in restrained joint applications.

In most instances, careful planning and/or measuring ahead to position required field cuts in unrestrained sections of a pipeline can eliminate the need for any field-fabricated restrained joints. Also, it is generally and technically preferable in restrained joint areas to restrain field-cut joints, when available, with restrained joints that only require a standard spigot end, which eliminates the need for field welding.

## Ball and Socket Joints

Ductile Iron pipe with boltless ball and socket joints is an extremely versatile product for use in subaqueous construction. Important in this context are the extreme toughness of heavy Ductile Iron wall thicknesses and the flexibility and the restraint against joint separation provided by the ball and socket.

The ball and socket joints available for Ductile Iron pipe are boltless. They consist of a precision-machined ball that fits into a machined socket, a rubber gasket to provide a pressure-tight seal, and a retainer ring that provides longitudinal restraint. The joint is designed so that the rubber gasket is properly compressed and the joint is leak-free throughout the full range of deflection. Four configurations of this type joint are shown in Figure 8. Maximum deflection is 15° per joint in sizes up to and including 24-inch pipe; in sizes 30-inch and larger, maximum deflection varies from 12° to 15°. At maximum deflection, the joint remains pressure-tight and retains the full flow area available in the undeflected joint.

The versatility of the ball and socket pipe allows the installer to devise installation methods to accommodate the particular conditions of his job and equipment. Further discussion and general installation methods are presented in DIPRA's publication "Ductile Iron Pipe Subaqueous Crossings."

## Grooved and Shouldered Joints

The grooved joint uses a bolted, segmental, clamp-type, mechanical coupling having a housing that encloses a U-shaped rubber gasket. The housing locks the pipe ends together and compresses the gasket against the outside of the pipe ends. The ends of the pipe are machine grooved to accept the housing. Grooved joints may be furnished as either rigid or flexible joints and are used mainly for aboveground applications. The shouldered joint is similar except that the pipe ends are shouldered instead of grooved. These joints in sizes 4-inch through 24-inch are covered in AWWA/ANSI C606, which defines material requirements, general design criteria, pipe-grooving details, and coupling test requirements. Two configurations of these type joints are shown in Figure 9.

## Conclusion

Ductile Iron pipe has a wider variety of joints available than any other piping material. This gives Ductile Iron pipe greater versatility and flexibility in pipeline design and installation to accommodate the particular conditions on the drawing board and at the job site. These joints are time-proven to be strong, dependable, and bottletight. This is just one of the many reasons why utilities and consulting engineers know that Ductile Iron pipe is the right decision.

Note: Due to limited space, only a few select joints were shown in this article. For a complete assemblage of joints available for Ductile Iron pipe, see the Ductile Iron Pipe Research Association's "Installation Guide for Ductile Iron Pipe," and manufacturer's literature.

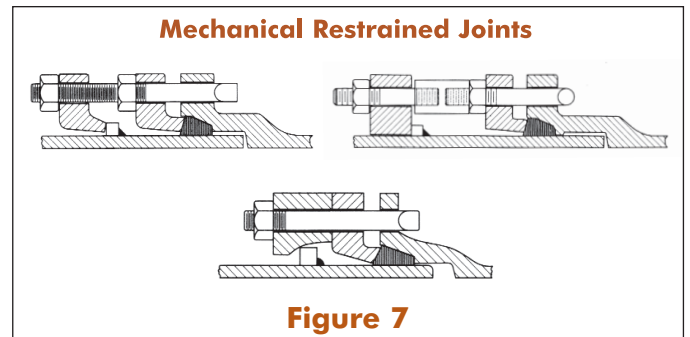

Figure 7

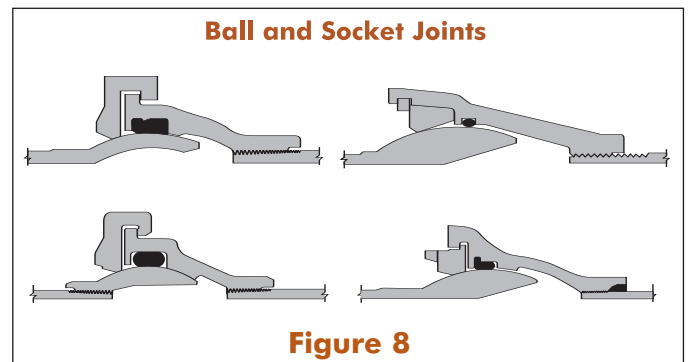

Figure 8

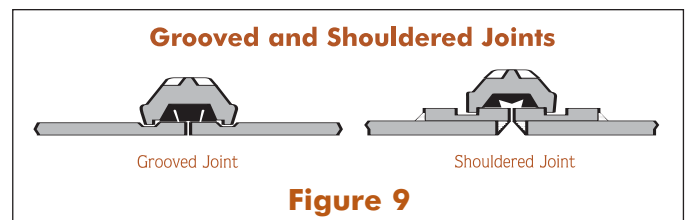

Figure 9

## DIPRA MEMBER COMPANIES

American Cast Iron Pipe Company  
P.O. Box 2727  
Birmingham, Alabama 35202-2727

Atlantic States Cast Iron Pipe Company  
183 Sitgreaves Street  
Phillipsburg, New Jersey 08865-3000

Canada Pipe Company, Ltd.  
1757 Burlington Street East  
Hamilton, Ontario L8N 3R5 Canada

Clow Water Systems Company  
P.O. Box 6001  
Coshocton, Ohio 43812-6001

McWane Cast Iron Pipe Company  
1201 Vanderbilt Road  
Birmingham, Alabama 35234

Pacific States Cast Iron Pipe Company  
P.O. Box 1219  
Provo, Utah 84603-1219

United States Pipe and Foundry Company  
P.O. Box 10406  
Birmingham, Alabama 35202-0406

# DUCTILE IRON PIPE

## RESEARCH ASSOCIATION



An association of quality producers dedicated to highest pipe standards through a program of continuing research.

245 Riverchase Parkway East, Suite O  
Birmingham, Alabama 35244-1856  
Telephone 205 402-8700 FAX 205 402-8730  
[www.dipra.org](http://www.dipra.org)

**DUCTILE IRON PIPE** **THE RIGHT DECISION**



Manufactured from recycled materials.